

Power Quality control in Multi Bus Feeder Distribution System using Generalized-UPQC

Mr. Atul Kumar Lal, Mr. Arun Kumar Srivastava, Mr. Roshan Thakur

Abstract—Power quality problem is an occurrence manifested as a nonstandard voltage, current or frequency that results in a failure or a mis-operation of end user equipment. With Power quality Problem utility distribution networks, industrial load, sensitive load etc are suffered. With the restructuring of power systems and with shifting trend towards distributed and dispersed generation, the issue of power quality is going to take new dimensions. To overcome the problem related to power quality Custom power devices are introduced. This work analyses the power flow of a three-feeder/multi-bus distribution system by a custom Generalized Power Quality Conditioner (GUPQC). The GUPQC has been realized by three voltage source converters (VSCs) coupled back-to-back through a common DC-link capacitor on the DC-side. One feeder was controlled by the shunt compensator, whereas each of the other two feeders was controlled by the proposed novel series compensator.

The GUPQC has the capability to simultaneously compensate voltage and current quality problems of a multi-bus/three-feeder distribution system. Besides that, the power can be transferred from one feeder to other feeders to compensate for poor power quality problems. Extensive simulation studies were carried out by using MATLAB/SIMULINK software to establish the ability of the GUPQC to improve power quality of the distribution systems under distorted supply voltage conditions.

Index Terms—Voltage and current source inverter, Shunt and series compensators, GUPQC, Power quality.

I. INTRODUCTION

In today's world there is great importance of electrical energy as it is the most famous form of energy and all are massively relying on it. Without supply of electricity life cannot be imagined. At the same time the quality and continuousness of the electric power supplied is also very important for the efficient functioning of the end user equipment. Many of the commercial and industrial loads require high quality undisturbed and constant power. Thus maintaining the qualitative power is topmost important in today's world. Due to power electronics devices there is serious effect on quality and continuousness of electric supply. Because of power electronics devices there is uninterrupted power supply, flicker, harmonics, and voltage fluctuations etc. There is also PQ problems such as voltage rise/dip due to network faults, lightning, switching of capacitor banks. With the excessive uses of non-linear load (computer, lasers, printers, rectifiers) there is reactive power disturbances and harmonics in power distribution system. It is very essential to overcome this type of problems as its effect may increase in future and cause adverse effect. Traditionally passive filters were used for reactive power disturbances and harmonics generation but there are many problems with them like they are large in size, resonance problem, and effect of source impedance on performance. The Smart Grid concept and its implementation have a significant influence on the modern multi-feeder distribution system. Power quality (PQ) is the major concern of the

distribution system users concerning the application of sensitive critical loads. At the same time, fully sinusoidal voltage and currents with a constant frequency are mandatory in same industrial sectors for the proper production process. The reliability of the operation of sensitive critical loads which does not tolerate disturbances in the supply system is essentially based on power supply quality. By integrating power electronic converters-based custom power devices in the existing distribution supply systems, it is possible to supply undistorted high quality power to sensitive loads in industrials or commercial centers. In order to overcome the PQ related problems, a unified power quality conditioner (UPQC) [1-3], by using series and shunt active power filters has been proposed to mitigate voltage and current imperfections in a single-feeder distribution system. Unfortunately, the UPQC cannot provide power quality solutions for multi-bus/multi-feeder distribution systems.

Based on the concept and applications of the flexible AC transmission systems (FACTS), devices in transmission lines the concept of the interline power flow controller (IPFC) and the generalized unified power flow controller (GUPFC) [4, 5] can be extended to the multi-bus/multi-feeder distribution systems. Along the same lines, extended version of the transmission line IPFC called as an interline unified power quality conditioner (IUPQC) consisting of two VSCs, one in the shunt to regulate the bus voltage of the one feeder in distribution system and the other in the series to regulate the voltage across a sensitive load of the other feeder, was proposed in [6]. A multi-converter unified power quality conditioner (MC-UPQC) having three VSCs connected back-to-back through a common DC-link capacitor was reported in [7] to compensate for both the current and voltage imperfections in one feeder and the voltage imperfections in the other feeder. Extended version of transmission line GUPFC is proposed in [8] for PQ improvement of a multi-bus/ three-feeder distribution system called, GUPQC which was realized by three VSCs connected back-to-back by a common DC-link capacitor on the DC side. By coupling three VSCs in back-to-back configurations the GUPQC can be operate with more flexibility and allow the active power to circulating from one VSC to the other to improve PQ of three-feeder/multi-bus distribution system. To benefit from the exchange of power between the feeders, one of the VSCs in the GUPQC system was connected in shunt to a feeder through a coupling transformer and the other two VSCs, each in series with a feeder, are connected to the other two feeders through series injection transformers. By this connection, the proposed GUPQC will simultaneously compensating voltage and current imperfections in multi-bus/three-feeder DS. Besides that, the power can be transferred from one feeder to other feeders to compensate for voltage and current quality problems of the system.

This present paper has addressed the power flow analysis and compensation performance of the GUPQC connected to a multi-bus/three-feeder distribution system based on the proposed new controller strategy for series compensators.

II. LITERATURE REVIEW

Purpose of literature survey is to collect the published information through the various research papers.

Power distribution systems should provide their customers with an uninterrupted flow of energy at smooth sinusoidal voltage at the contracted magnitude level and frequency. However in power systems, especially the distribution systems have many nonlinear loads, which significantly affect the quality of power supplies [8].

Arindam Ghosh et al. [10] Comprehensive review of compensating type custom power devices, issues of power quality, survey of power quality problems, standards and indices proposed by different agencies and different approaches to improve power quality from time to time .

Juan W. Dixon et al. [11] presented a series active power filter working as a sinusoidal current source, which is in phase with the mains voltage. The amplitude of the fundamental current in the series filter is controlled with the help of error signal generated between the load voltage and a pre-established reference. The control provides the effective correction of power factor, harmonic distortion, and load voltage regulation.

H. Hingorani et al. [12] presented the term custom power means the use of power electronics controllers for distribution systems. The custom power increases the quality and reliability of the power that is delivered to the customers. Customers are increasingly demanding quality in the power supplied by the electric company.

Malabika Basu et al. [13] suggested that Unified Power Quality Conditioner (UPQC) is one of the major custom power solutions that are capable of mitigating the effect of supply voltage sag at the load end or the Point of Common Coupling (PCC). It also prevents load current harmonics from entering the utility and corrects the input power factor of the load. The control of series compensator is such that it injects voltage in quadrature advance to the supply current, so that no active power is consumed by the series compensator at steady state.

Gu Jianjun et al. [14] presented that the Unified power quality conditioner (UPQC), which aims at the integration of series-active and shunt-active power filters. The main purpose of a UPQC is to compensate for voltage imbalance, reactive power, negative-sequence current and harmonics.

Ke Dai et al. [15] presented a three-phase three-wire series-parallel compensated universal power quality conditioner based on two voltage-source converters controlled separately by two digital signal processors. Different from those popular active power filters, the series voltage-source converter is controlled as a fundamental sinusoidal current

source in phase with the utility, while the parallel voltage-source converter is controlled as a fundamental sinusoidal voltage source with constant voltage and constant frequency. It is shown that the total harmonic distortion values of input current and output voltage are both less than 5% with almost unity input power factor, even in the case of distorted utility and feeding reactive and non-linear loads.

Jiangyuan Le et al. [16] presented nonlinear control strategy for unified power quality conditioner (UPQC) with better stability and dynamic performance in comparison with PI control and classical decoupled strategy. The analysis is based on the rotating reference frame, and the nonlinear property of UPQC mode is partly dealt through the exact linearization via feedback. The operation of control circuit has been explained using MATLAB software and simulation. The validity of control strategy is studied through simulation results.

Luis F.C. Monteiro et al. [17] presents a three-phase three-wire system in which unified power quality conditioner is used and for control purpose a dual control strategy is used for series active filter. The work presented a control strategy for shunt-active filter that guarantees sinusoidal, balanced and minimized source currents even under unbalanced and / or distorted system voltages. Then, this control strategy was extended to develop a dual control strategy for series-active filter. The paper develops the integration principles of shunt current compensation and series voltages compensation, both based on instantaneous active and non-active powers, directly calculated from a-b-c phase voltages and line currents.

G. Siva Kumar et al. [18] presented a device that can be used to enhance power quality i.e. Unified power quality conditioner (UPQC). The UPQC is a versatile device which could function as series active filter and shunt active filter. It can fulfill different objectives like, maintaining a balanced sinusoidal (harmonic free) nominal voltage at the load bus, eliminating harmonics in the source currents, load balancing and power factor correction.

III. GUPQC

A multi-bus / three-feeder distribution system which supplies a sensitive nonlinear load (load1) by feeder1 and two other sensitive loads (load2 and load3) connected to the other two feeders is shown in Figure 1(a). Each feeder is represented by the equivalent impedance which denoted by ZS. The shunt compensator, VSC1 is operates as a controlled current source which employed to compensate the harmonic currents of feeder1, the reactive power required by the load1 and to support the real power required by the two series compensators. At the same time, the DC-link capacitor voltage is to be maintained at a desired level.

The two series compensators, VSC2 and VSC3, are used as controlled voltage sources to protect the two sensitive loads (load2 and load3) against voltage imperfections. Each of the series compensators is designed to provide the missing voltage between the supply side and the ideal load side voltages such that the load bus voltage of the respective feeder is always sinusoidal and at desired level.

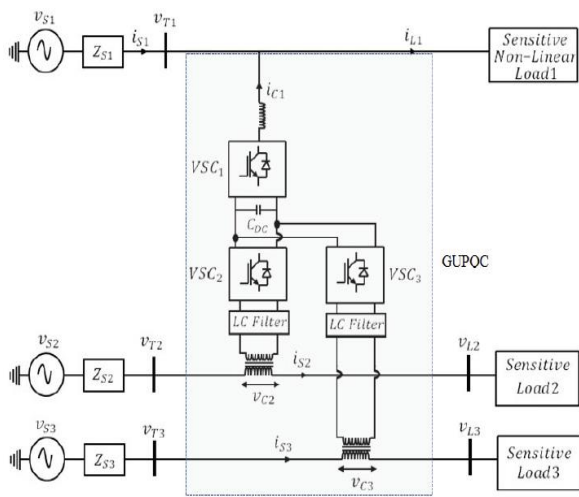

(a) Typical Mode

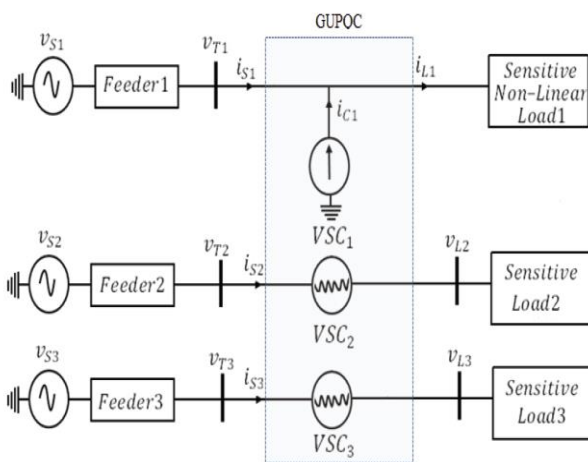

(b) Equivalent circuit

Figure 1: GUPQC connected to multi-bus/three-feeder distribution system

In Figure 1, V_{S1} , V_{S2} , V_{S3} , V_{Sn} are the supply, terminal, load, and compensation voltages respectively, and I_{Sn} , I_{Ln} , I_{Cn} are the supply, load and compensation currents respectively, while the subscript n is for the feeder index. Each VSC in Figure 3.1 consists of three single-phase H-bridge converters supported by a common DC-link bus voltage. The AC side of the shunt compensator, VSC1 is connected to the distribution system through a commutation reactor and a single-phase transformer, while the AC side of each of the series compensators, VSC2 or VSC3, is connected to the distribution system through a series injection transformer and L-C filter which is used to prevent the flow of switching harmonics into the distribution system. The selection of L and C was based on the technique presented in [18].

IV. POWER FLOW ANALYSIS

The power flow analysis was carried out under normal and disturbed conditions of the feeders based on the fundamental components of voltage and current. Based on Figure 3.1(b) by considering the lagging power factor loads on the feeders, the load voltages and currents can be written as shown in (1) and (2) respectively:

$$V_{Ln} = V_{Ln} \angle 0^\circ \quad (1)$$

$$i_{Ln} = I_{Ln} \angle -\phi_{Ln} \quad (2)$$

Where, the feeder index $n = 1, 2, \text{ or } 3$. In case of system voltage sag/swell etc., the source voltage fluctuation factor, x_n can be defined by (3).

$$x_n = \frac{V_{Sn} - V_{In}}{V_{Ln}} \quad (3)$$

Then, the injected voltage by the series compensators can be calculated by (4).

$$V_{Cn} = V_{Ln} - V_{Sn} = x_n V_{Ln} < 0^\circ \quad (4)$$

Under consideration of the lossless power of GUPQC system, the active power demanded by the loads should be equal to the active power supplied by the sources. Then, the system active power is expressed by using equation (5):

$$V_{Sn} I_{Sn} V_{Ln} (1 + x_n) I_{Sn} = V_{Ln} I_{Ln} \cos \phi_{Ln} \quad (5)$$

Thus, the source current becomes:

$$I_{Sn} = \frac{I_{Ln}}{(1 + x_n)} \cos \phi_{Ln} \quad (6)$$

From (6) both I_{Ln} and ϕ_{Ln} are constant for a particular type of load. Thus, the source current depends on the source voltage fluctuation factor x_n . If the supply side voltage of feeder2 or feeder3 is subjected to the voltage sag / swell etc., the feeder1 source current can be expressed as:

$$I_{S1} = \frac{I_{L1}}{(1 + x_n)} \cos \phi_{L1} - \frac{x_2 V_{L2} I_{L2}}{(1 + x_2) V_{L1}} \cos \phi_{L2} - \frac{x_3 V_{L3} I_{L3}}{(1 + x_2) V_{L1}} \cos \phi_{L3} \quad (7)$$

The compensation current by the shunt compensator which includes active and reactive current components can be expressed by (8):

$$I_{C1} = I_{S1} - I_{L1} \angle -\phi_{L1} = (I_{S1} - I_{L1} \cos \phi_{L1}) + j(I_{L1} \sin \phi_{L1}) \quad (8)$$

Then, the complex power of the shunt compensator is:

$$S_{VSC1} = V_{L1} I_{C1} = V_{L1} (I_{S1} - I_{L1} \cos \phi_{L1}) + j(V_{L1} I_{L1} \sin \phi_{L1}) \quad (9)$$

$$P_{VSC1} = V_{L1} (I_{S1} - I_{L1} \cos \phi_{L1}) \quad (10)$$

$$Q_{VSC1} = V_{L1} I_{L1} \sin \phi_{L1} \quad (11)$$

Feeder2 compensator, VSC2, active and reactive powers:

$$P_{VSC2} = -x_2 V_{L2} I_{L2} \cos \phi_{L2} \quad (12)$$

$$Q_{VSC2} = x_2 V_{L2} I_{L2} \sin \phi_{L2} \quad (13)$$

Feeder3 compensator, VSC3, active and reactive powers:

$$P_{VSC3} = -x_3 V_{L3} I_{L3} \cos \phi_{L3} \quad (14)$$

$$Q_{VSC3} = x_3 V_{L3} I_{L3} \sin \phi_{L3} \quad (15)$$

Based on the above active and reactive power equations, the power flow in the three feeders an analysis was carried out in the following case studies to show the ability of the GUPQC to maintaining the overall power balance in a multi-bus/three-feeder distribution system.

Case 1: In the normal operation condition of most of the distribution systems, the utility supplied the load active and reactive power demand, which puts an extra burden on the source to supply the load reactive power as seen in Figure 2(a).

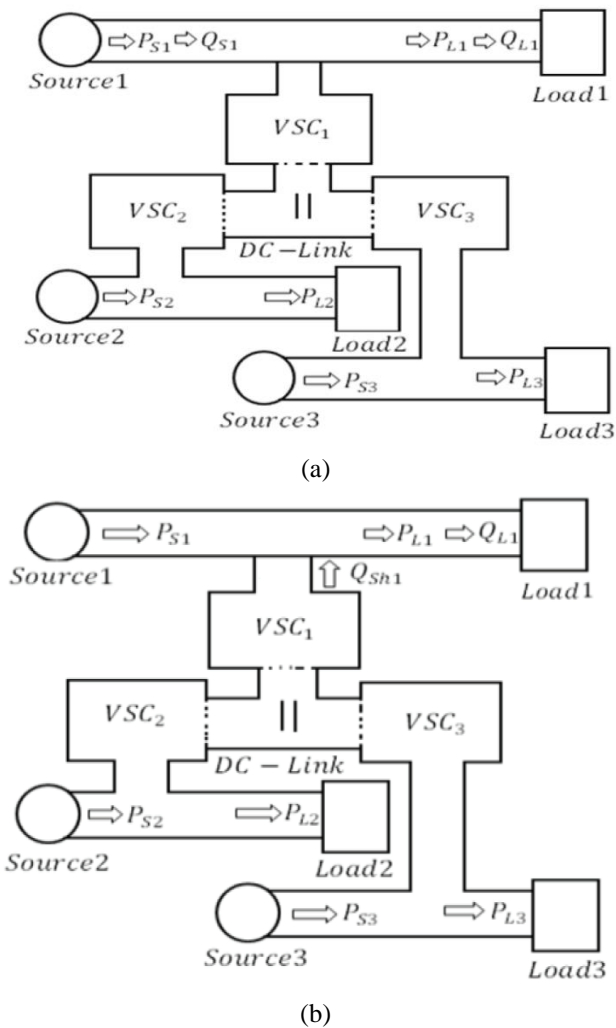

Figure 2: Normal operation condition: (a) GUPQC-OFF; (b) GUPQC-ON

As the GUPQC comes into the operation, and under assumption of, $x_2 = x_3 = 0$, i.e. $V_{Sn} = V_{Ln}$ based on (13), (14) and (15), $Q_{VSC1} = Q_{L1} = Q_{sh1}$ and $P_{VSC2} = P_{VSC3}$ which means that the reactive power required by sensitive nonlinear load1, is supplied by the shunt compensator such that no extra reactive power burden is put on the source1 during the voltage imperfections in feeder2 or feeder3. Figure 2(b) shows the power flow in this case.

Case 2: In this case, the power required by the load2 and load3 are assumed to be higher than the source capacities, such that, $x_2 < 0$; $x_3 < 0$, i.e. $V_{S2} < V_{L2}$; $V_{S3} < V_{L3}$. These conditions are possible during the supply system2 and supply system3 voltage sag. The active powers of feeder2 and feeder3 based on (14) and (15) become, $P_{VSC2} > 0$; $P_{VSC3} > 0$, this means that each of the series compensators is required to supply additional active power to the corresponding load to compensate for the source side voltage sag. It can be observed from (8) that, the feeder1 source side current increased above the normal rated current to maintain the DC-link voltage at the desired level or to maintain a power balance in the system. Figure 3 (a) represents the power flow in this case.

Case 3: In this case, the power supplied by the source2 and source3 to the sensitive load2 and sensitive load3, respectively, are assumed to be higher than the power demanded by two the loads such that, $x_2 > 0$; $x_3 > 0$ i.e. $V_{S2} > V_{L2}$; $V_{S3} > V_{L3}$. These conditions are possible during

the supply voltage swell. The active power of feeder2 and feeder3 based on (14) and (15) becomes, $P_{VSC2} < 0$; $P_{VSC3} < 0$, which means that the series compensators in feeder2 and feeder3 absorbed the extra active power from the source sides to compensate for the voltage swells. It can be observed from (8) that the feeder1 source side current decreased below the normal rated current to maintain the DC-link voltage at the desired level or to maintain a power balance. Figure 2(b) shows the power flow in this case.

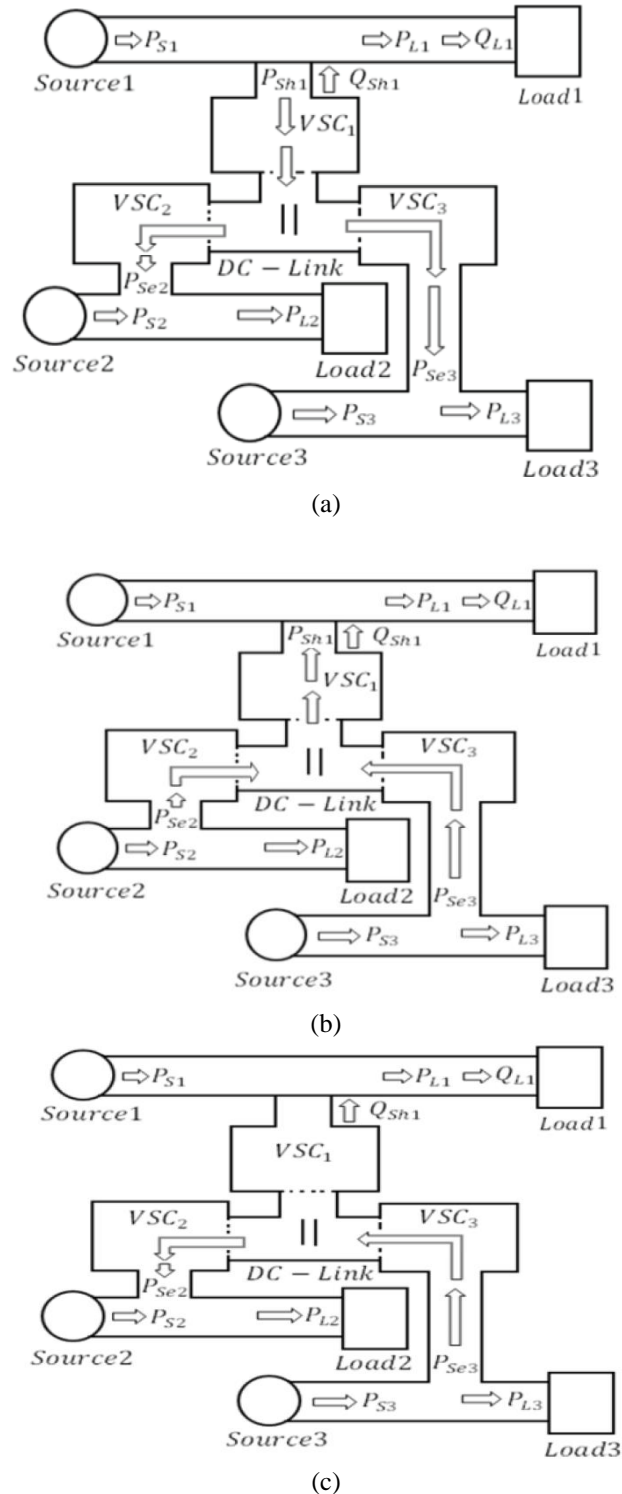

Figure 3: GUPQC-ON: (a) Voltage Sag condition; (b) Voltage swell condition; (c) Voltage Sag/swell condition

Case 4: In this case, the power required by the sensitive load2 is assumed to be higher than the source capacity $x_2 < 0$, i.e. $V_{S2} < V_{L2}$ (voltage sag), and the power supplied by

the source3 to the sensitive load3 is higher than the power demanded by the load (voltage swell), $x_3 > 0$, i.e. $VS_3 > VL_3$. Based on (13) and (14), the active powers of the two feeders become, $PVSC_2 > 0$; $PVSC_3 < 0$, which means that the series compensator of feeder2, in this case, supplied active power to the load2 to compensate for the voltage sag whereas the series compensator of feeder3 absorbed the source extra active power to compensate for the voltage swell. It can be observed from (8) that, the feeder1 source side current did not change and the power required by the load2 is supplied by the series compensator of feeder3 through the DC-link capacitor, such that the overall power is balanced. Figure 3(c) shows the power flow in this case.

V. RESULT AND ANALYSIS

The simulation model of GUPQC test model in MATLAB/SIMULINK platform is illustrated as in Figure 4.

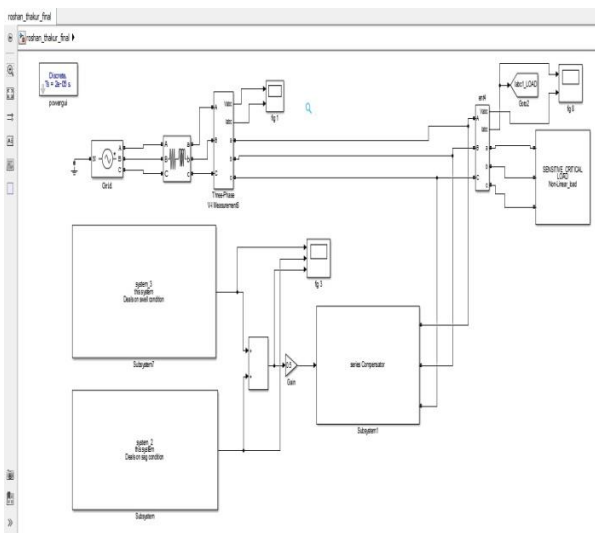

Figure 4: Simulation model of GUPQC system in MATLAB/SIMULINK platform

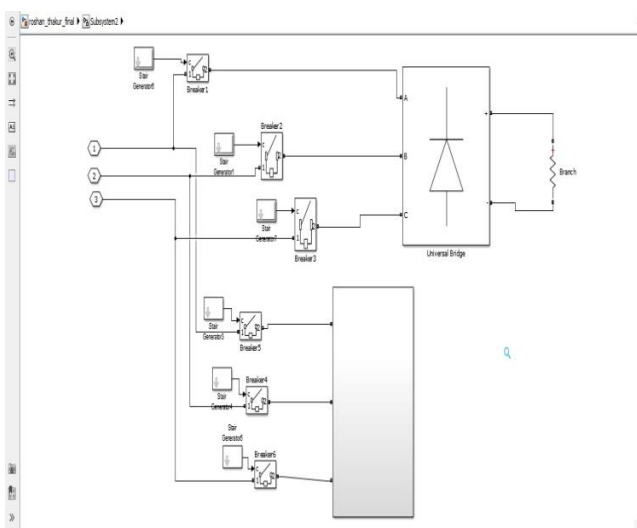

Figure 5: Simulation model of Sensitive Critical Load system in MATLAB/SIMULINK platform

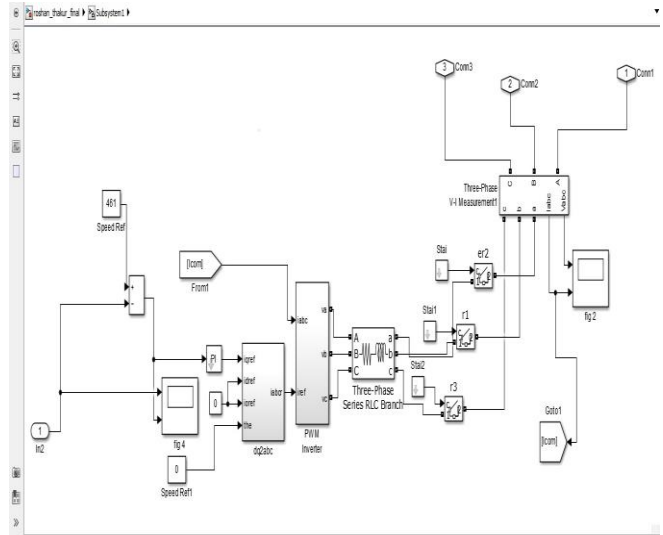

Figure 6: Simulation model of Series Compensator in MATLAB/SIMULINK

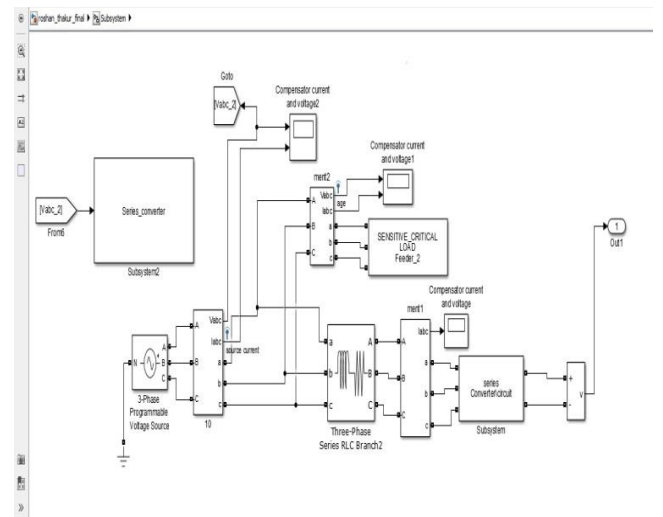

Figure 7: Simulation model of Subsystem2 Sag Condition in MATLAB/SIMULINK

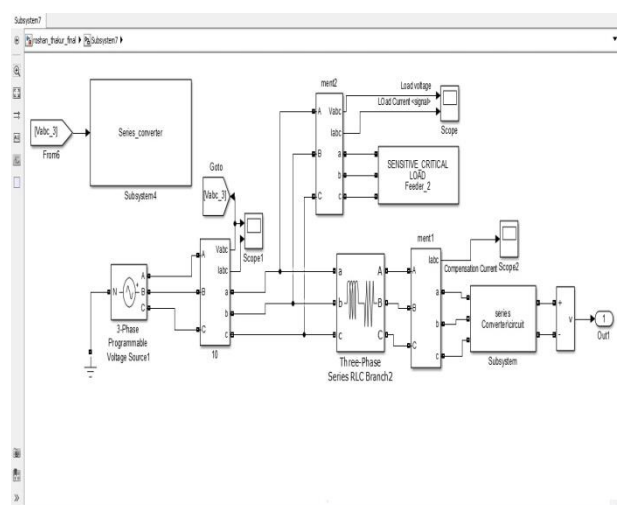

Figure 8: Simulation model of Subsystem2 Swell Condition in MATLAB/SIMULINK

As the sensitive nonlinear load1 is a combination of linear and non-linear loads, initially the linear part was connected to the system. The shunt compensator was put into the operation at $t_1 = 0.10s$ as seen in Figure 9 and immediately started injecting the compensation currents, i.e., non-active current component. To compensate for current harmonics, the non-linear part of the sensitive nonlinear load1 was connected at $t_2 = 0.15s$.

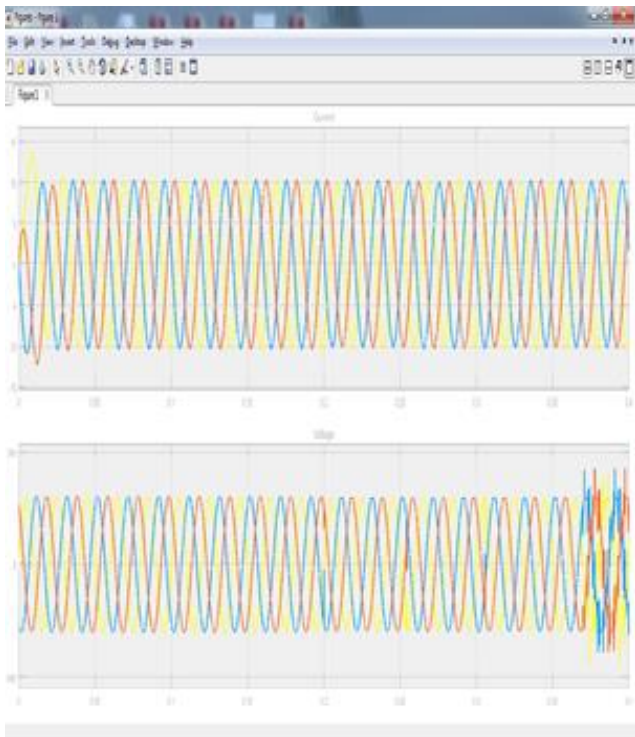

Figure 9: Final source voltage, source side current and compensation current

The distortion of the supply voltages besides the voltage sag/swell was compensated with excellent compensating characteristics of the GUPQC based on the proposed controller. The response of the shunt compensator to the changes in the system voltages (power flow) was presented as in Figure 10 in terms of the source side current of feeder1 and DC-link capacitor voltage.

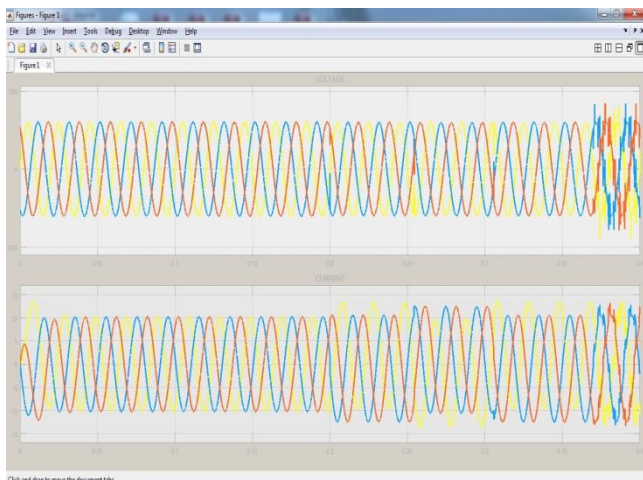

Figure 10: Source voltage, source side current and compensation current without any condition

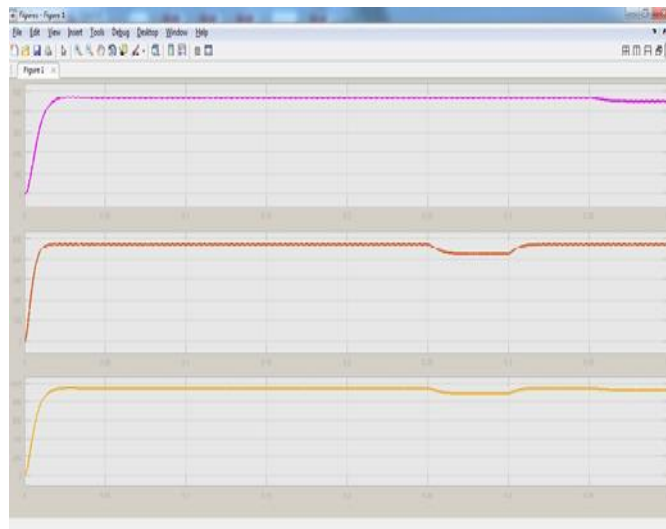

Figure 11: Source voltages with condition

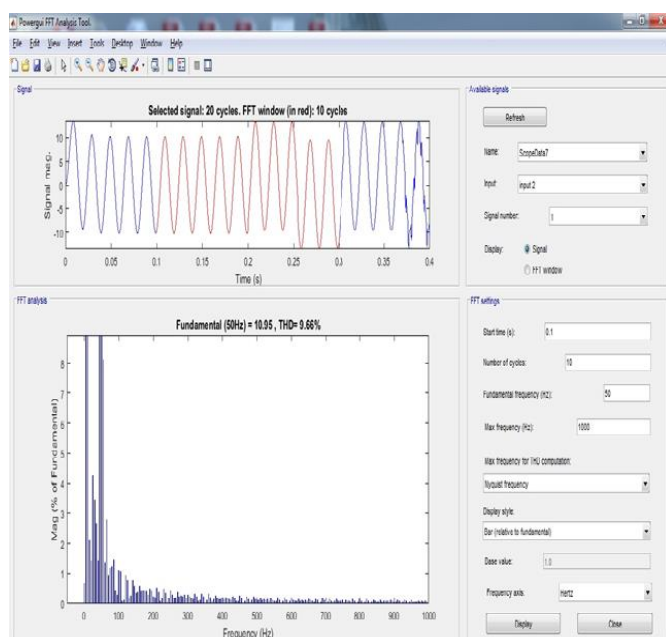

Figure 12: THD level of the source and load voltages

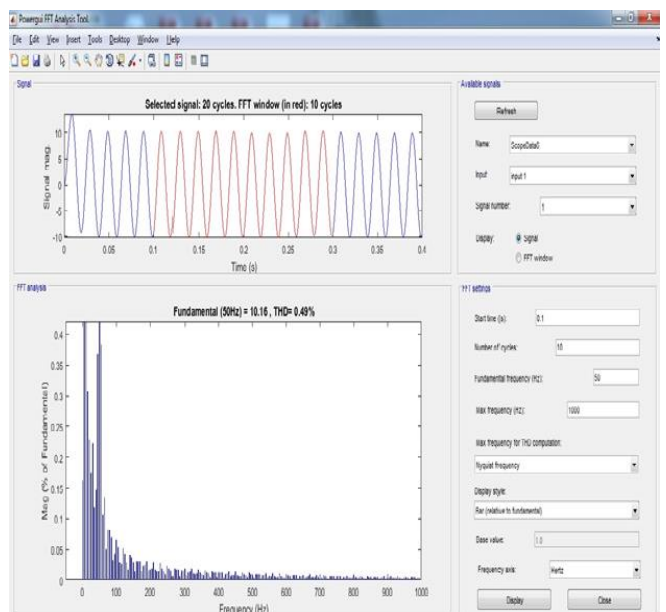

Figure 13: THD level of the source and load voltages

VI. CONCLUSION

In this work the power flow analysis through the GUPQC connected to the multi-bus/three-feeder distribution systems was carried out. A new controller scheme for the series compensator of GUPQC based on the d-q theory to compensate for the source side voltage harmonics, voltage sag/swell and interruption was presented. The application of the proposed controller to compensate for voltage imperfections of the network and for the improvement of the power quality of the customer loads was validated by the simulation results. It has also been demonstrated that the shunt compensator based on the developed controller effectively maintained the power balanced beside the DC-link capacitor at the desired level.

Mr. Atul Kumar Lal Asst. Professor (Guest Faculty), Department of Electrical Engineering, ,Rajkiya Engineering College , Kannuj, India.

Mr. Arun kumar Srivastava, Assistant Professor, Department of Electrical Engineering, ,RRIMT , Lucknow, India.

Mr. Roshan Thakur, Assistant Professor, Department of Electrical Engineering, ,RRIMT , Lucknow, India

References

- [1] H. Fujita and H. Akagi, "The unified power quality conditioner: the integration of series and shunt-active filters," IEEE Trans. Power Electronics, vol. 13, no. 2, pp. 315-322, Mar. 1998.
- [2] B. Han, B. Bae, S. Baek and G. Jang, "New configuration of UPQC for medium-voltage application," IEEE Trans. Power Delivery, vol. 21, no. 3, pp. 1438- 1444, Jul. 2006.
- [3] V. Khadkikar and A. Chandra, "A novel structure for three-phase four-wire distribution system utilizing unified power quality conditioner," IEEE Trans. Industrial Application, vol. 45, no. 5, pp. 1897-1902, Sept./Oct. 2009.
- [4] L. Gyugyi, K. K. Sen, and C. D. Schauder, "Interline power flow controller concept: a new approach to power flow management in transmission systems," IEEE Trans. Power Delivery, vol. 14, no. 3, Jul. 1999.
- [5] X. P. Zhang, E. Handschin and M. Yao, "Modeling of generalize unified power flow controller (GUPFC) in a nonlinear interior point OPF," IEEE Trans. Power Systems, vol. 16, pp. 367-373, Aug. 2001.
- [6] A.K. Jindal A. Ghosh, and A. Joshi, "Interline unified power quality conditioner," IEEE Trans. Power Delivery, vol. 22, pp. 364-372, 2007.
- [7] H. R. Mohammadi, A. Y. Varjani and H. Mokhtari, "Multiconverter unified power quality conditioner system MC-UPQC," IEEE Trans. Power Delivery, vol. 24, no. 3, pp. 1679-1686, Jul. 2009.
- [8] K. R. Padiyar, "Facts Controllers in Power Transmission and Distribution", New Age International Publishers, 2007.
- [9] Arindam Ghosh and Gerard led which, "Power Quality Enhancement Using Custom Power Devices", Kluwer Academic Publishers, 2002.
- [10] Juan W. Dixon, Gustavo Venegas and Luis A. Mor an, "A Series Active Power Filter Based on a Sinusoidal Current-Controlled Voltage-Source Inverter" IEEE Transactions on Industrial Electronics, Vol. 44, Issue: 5, Page(s): 612 -620, October 1997.
- [11] H. Hingorani "Introducing Custom Power" IEEE Spectrum, Vol.32, Issue: 6,Page(s): 41-48, June 1995.
- [12] M. Basu, S.P. Das and G.K. Dubey, "Performance study of UPQC-Q for load compensation and voltage sag mitigation", Conference of the Industrial Electronics Society Vol. 1, page(s): 698 -703,2002.
- [13] GuJianjun, XuDianguo, Liu Hankui and Gong Maozhong, " Unified Power Quality Conditioner (UPQC): the Principle, Control and Application", Conference on Power Conversion Vol Page(s): 80 -85, 2002.
- [14] Ke Dai , Peiguo Liu, Guixin Wang, Shanxu Duan and Jian Chen, "Compensated Universal Power Quality Conditioner" IEEE Conference on Applied Power Electronics and Exposition, 2004. APEC'04. Nineteenth Annual, Vol. 1, page(s): 601 - 606, 2004 .
- [15] JiangyuanLe , YunxiangXie , Zhang Zhi and Cheng Lin " A Nonlinear control strategy for UPQC" International Conference on Electrical Machines page(s): 2067 - 2070, 2008 .
- [16] F.C. Monteiro, Mauricio Aredes and Joao A. Moor Neto "A Control Strategy for Unified Power Quality Conditioner", IEEE International Symposium on Industrial Electronics, vol. 1, Page(s): 391 -396, 2003.
- [17] P. A. Dahono, A. Purwadi, A., Q. Quamaruzaman, "An LC filter design method for single-phase PWM inverters," in Proceedings of IEEE International Conference on Power Electronics and Drive Systems, pp. 571 -576, 1995.