

Hybrid Inverter with Wind and Solar Battery Charging

Srashti Layyar, Tushar Saini, Abhishek Verma, Ashwani Kumar

Abstract— This paper presents solar and wind hybrid energy system with battery storage along with AC mains supply. This, configuration allows the three sources to the battery as well as supply the load separately or simultaneously depending on the availability of the energy sources. In many rural area of India, electricity has not reached their home yet as well as many people face load shedding problem. A hybrid design of battery charging system and its implementation has been explained in this paper. Besides AC mains supply charging, solar PV, wind energy also charges the battery whenever it is available through a charge controller. This system ensures continuous power supply and faster charging of battery. The system has been designed to suit a typical Indian scenario where there is power shortage which result in scheduled and unscheduled power shedding. Today, the world is progressing at quite fast rate with the use of the conventional source of energy. The two majors disadvantage of using them are the environmental pollution caused by its use and its limited quantity. On the other hand, the non-conventional source of energy is available in plenty, free of cost and pollution free. So, it's better to switch on to the non-conventional source of energy, these includes solar energy, wind energy, wave energy, biomass etc. This paper deals with the energy conservation technique which is a combination of two non-conventional source of energy i.e., Solar and Wind energy.

Index Terms— Battery; Hybrid; Charging; Solar; AC mains supply; Wind.

I. INTRODUCTION

Energy is the key input to drive and improve the life cycle. Primarily, it is the gift of nature to the mankind in various forms. The consumption of energy is proportional to the progress of the mankind with ever growing population, improvement in the living standard of the humanity, industrialization of the developing countries, the global demand for energy is expected to increase rather significantly in the near future. [1]

Remote rural areas, especially in developing countries, are in great need of affordable and reliable electricity to achieve development. Hybrid system can provide a steady community-level electricity service, such as village electrification, offering also the possibility to upgraded through grid connection in the future. [3]

The global search and the rise in the cost of conventional fossil fuel is making supply-demand of electricity product

almost impossible especially in some remote areas. Generator which are often used as an alternative to conventional power supply systems are known to be run only during hours of the day, and the energy cost of fueling them is increasingly becoming difficult if they are to be used for commercial purposes. There is a growing awareness that renewable energy such as photovoltaic system and Wind power have an important role to play in order to save the situation. [2]

Environment friendly solutions are becoming more prominent than ever as a result of concern regarding the state of our deteriorating planet. With increasing concern of global warning and the depletion of fossil fuels preserves. Many are looking at sustainable energy solution to preserve the earth for future generations. Other than hydro power, wind and PV energy holds the most potential to meet our energy demands. [4]

The solar energy technology, a novel technology for the people, provides a superior energy for cooking, lighting and many other purposes. There are divergent opinions regarding the application of solar and wind energy as the best alternatives as well as renewable source of energy. The system utilizing combination of both solar and wind energy is found to be more efficient than rather solar or wind alone. [5]

II. HYBRID ENERGY SYSTEM

Hybrid renewable energy systems (HRES) are becoming popular as stand-alone power systems for providing electricity in remote areas due to advances in renewable energy technologies and subsequent rise in prices of petroleum products. A hybrid energy system, or hybrid power, usually consists of two or more renewable energy sources used together to provide increased system efficiency as well as greater balance in energy supply.

Hybrid system can provide a steady-community level electricity service such as village electrification, offering also the possibility to be up graded through grid connection in future. A hybrid system uses a combination of energy producing components that provide a constant flow of uninterrupted power. Hybrid wind turbine and photovoltaic module, offer greater reliability than any one of them alone because the energy supply does not depend entirely on any one source. Wind and solar hybrids also permit use of smaller, less costly components than would otherwise be needed if the system depended on only one of power source. This can substantially lower the cost of a remote power system. [6]

III. MODE OF OPERATION

- When all solar, wind and AC mains supply are available then preference is given to solar power.
- When solar power is available below the pre-set value, then preference switches to wind power.

Srashti Layyar, Department of Electrical and Electronics Engineering
COER, Roorkee, India

Tushar Saini, Department of Electrical and Electronics Engineering
COER, Roorkee, India

Abhishek Verma, Department of Electrical and Electronics Engineering
COER, Roorkee, India

Ashwani Kumar, Department of Electrical and Electronics Engineering
COER, Roorkee, India

- If both solar power and wind power is available in below the pre-set value the preference is given to AC mains.

IV. METHODOLOGY

A. A Hybrid Battery Charging System

A hybrid battery charging system which uses solar and wind energy along with AC mains supply is currently in use which consist of a charge controller whose design is customized to regulate the voltage and current according to the rating of the battery. Other design involve supply from AC mains that rectify and regulate the utility grid supply to charge the battery. This paper describes a hybrid design that incorporates both the above-mentioned method of battery charging. [7]

B. DESIGN

- Solar Panel:** A 5W peak solar panel has been used to charge the battery. To make 12V battery compatible with the solar panel, the voltage rating of solar panel is used of higher rating. Therefore, 20V is chosen.
- Charge Controller:** A charge controller consisting of a transformer of suitable rating and a boost converter is used which protect battery from being overcharged, which can shorten their life as the life expectancy of the equipment being powered. A charge controller design involves a boost converter for regulating the output obtained from solar panel and windmill to ensure maximum efficiency.

Components of charge controller:

- Transformer:** A step down transformer of rating 1A is used in this module.
- Boost Converter:** Boost converter is also known as step up converter. It is the basic DC to DC converter configuration with an output voltage higher than its input voltage. The DC input to a boost converter can be from many sourced as well as batteries, such as rectified AC from the mains supply, or Dc from the solar panels, fuels cells, dynamos and DC generators. The boost converter is different to the buck converter in that its output voltage is equal to, or greater than its input voltage. However, it is important to remember that, as power (P)= voltage (V) * current (I), if the output voltage is increased, the available output current must decrease.

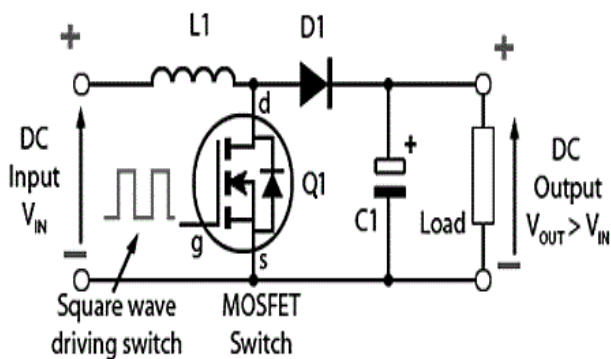

Figure 1: Input to the booster circuit

- Battery:** A 12V/7.5Ah, 5A battery is used. The battery is used is a lead-acid battery. It is charged from the power derived from solar panel, windmill and AC mains through a charge controller.

Primary functions of a battery are:

- Energy storage and autonomy.
 - Voltage and current stabilization.
- LCD:** An LCD of dimension (16*2) is used which is a very basic module (display module) used for DIY's purposes. Here it displays the voltage obtained from the different energy module.
 - Windmill:** A DC motor is used to operate the windmill and a hair dryer is used to produced wind speed sufficient to rotate the windmill and produce energy.
 - Diode IN4007:** It is the supervision of all other IN400X diodes. In this module it is generally used for filtering purposes.
 - Microcontroller AT89S52:** It is a low power, high performance CMOS 8-bit microcontroller which is manufactured using high density non-volatile memory technology. It is compatible with the industry standard 80C51 instructions set and pin out. AT89552 can be programmed in both ways either USART or ISP.
 - Relay Driver VLN2803:** It is used to drive the relay because the relay is an inductive load.
 - Operational Amplifier LN324:** It is used in this module as a comparator which compare the voltage coming from both the sources (solar and wind) with reference voltage or with each other.
 - Relay (12V):** Relay is used as a changeover switch not for protection purposes. Hence a least value rating relay 12V is chosen for this purpose.
 - Voltage Regulator LM7005:** A voltage regulator is used to maintain the output voltage at a constant value. 78XX series of fixed linear voltage regulator used to maintain such fluctuations, is a popular voltage regulator or IC. They are available in the voltage range of about (7-35V) and current rating of 1A.
 - Crystal Oscillator:** It is used in this module to produce a clock pulse through it to synchronize all the flip-flop present in the digital device i.e., microcontroller.

V. IMPLEMENTATION

Case 1: When all the four energy sources are available, our priority switches to solar energy i.e. we are extracting DC from solar system and then it is fed to battery and further converted into AC with the help of inverter and finally fed to AC loads.



Figure 2: Priority 1- Solar Power Supply

Case 2: In the absence of solar energy the priority switches to wind energy. Further scenario will remain same as in case 1.



Figure 3: Priority 2- Windmill Power Supply

Case 3: When both the renewable energy sources are absent, the priority goes to AC mains which will supply to the AC loads.



Figure 4: Priority 3 – Main Power Supply

Case 4: When none of the energies mentioned above are unavailable then the AC loads are operated by the battery.



Figure 5: Priority 4 – Generator Power Supply

A. Working of hardware model

The system employs three sources of energy to charge the battery i.e. solar energy, wind energy and ac mains supply. An electronic adopter is used which converts 220V AC into 12V DC to operate the basic circuit board. The filtration of this 12V DC is done by an electrolytic capacitor and a resistance connected across the voltage regulator LM7805 which further maintains the voltage at 5V. Microcontroller is used as a charge controller which controls the charging and discharging of battery. It also prevents overcharging of the battery. A crystal oscillator is also connected under the microcontroller which provides clock pulses to synchronize all the flip flops. When the sunlight falls on solar panel it produces electrical energy and it charges the battery through the charge controller. Similarly, when windmill rotates, battery is charged. But when both solar panel and windmill operates simultaneously then the power of individual sources is compared with a reference value with the help of an operational amplifier



Fig. 3.11 Hardware model

If voltage produced by solar is greater than reference voltage then solar energy is utilized in charging the battery and if voltage produced by wind is greater than the reference voltage then wind energy is utilized for battery charging. The voltage produced by different sources is displayed in an LCD module. If none of the energies are available then the battery is charged through AC mains supply, thus making the system uninterruptable. Three relays are used for the three sources which perform switching action.

VI. APPLICATIONS

1. Outdoor street lighting.
2. Lightning of commercial buildings. Rural and village lightnings.
3. Transmissions and communication towers and many more application are:
 - i. Monitoring system
 - ii. Irrigation
 - iii. Telecommunication system and etc.

VII. CONCLUSION

A hybrid power generation which comprises of four arrays, wind turbine with battery backup and power condition units has been discussed in this study to achieve a cost-effective system configuration.

Under the circumstance of power failure this hybrid system keeps the continuity of supply without producing any noise pollution, dislike any other power generating equipment.

The hybrid energy system designed to charge a battery has been implemented by utilizing solar, PV, wind energy and AC mains supply. It can be inferred from the above hybrid changing system is much suited for those areas where AC mains supply is insufficient and solar and wind energy are available is abundance.

REFERENCES

- [1] R. Chedid and S. Rahman, Unit sizing and control of hybrid wind-solar power systems. IEEE Transactions on energy conversion, Vol. 12, N°1, March 1997, pp. 79-85.
- [2] B.S. Borowy and Z.M. Salameh, Optimum photovoltaic array size for a hybrid wind/PV system. IEEE Transactions on energy conversion, Vol. 9, N°2, September 1994, pp. 482-488.
- [3] B.S. Borowy and Z.M. Salameh, Methodology for optimally sizing the combination of a battery bank and PV array in a wind/PV hybrid system. IEEE Transactions on energy conversion, Vol. 11, N°2, June 1996, pp. 367375.
- [4] F. Valenciaga and P. F. Puleston "Supervisor Control for a Stand-Alone Hybrid Generation System Using Wind and Photovoltaic Energy" iee transactions on energy conversion, vol. 20, no. 2, June 2005.
- [5] Z. Lubsony, Wind Turbine Operation in Electric Power Systems, Springer-Verlag, Germany, 2003.
- [6] Arjun A. K., Athul S., Mohamed Ayub, Neethu Ramesh, and Anith Krishnan, "Micro-Hybrid Power Systems – A Feasibility Study" Journal of Clean Energy Technologies, Vol. 1, No. 1, pp. 27-32, January 2013.
- [7] L. Barote and C. Marines cu "Renewable Hybrid System with Battery Storage for Safe Loads Supply" Paper accepted for presentation at the 2011 IEEE Trondheim Powertech.