

Design Techniques of Microwave Cavity and Waveguide Filters: A Literature Review

Asmita Mary Soreng, Dr. Agya Mishra

Abstract— This work reviews literatures concerning major techniques used in the design of cavity and waveguide filters particularly for microwave frequencies. Cavity and waveguide filters are widely used where high Q value and high power handling capability are essential. Advances have been achieved in this area in the last few decades. The design processes for each filter are reviewed and accompanied by the simulated and experimental results. A comparison of these filters in terms of passband and stopband performance is discussed. The SIW resonator is compared with other microwave resonators from the viewpoint of tradeoffs between loss and cost. The Q_u of an SIW cavity resonator is found to be in the range of 150~1000.

Index Terms— substrate integrated waveguide (SIW), low temperature co-fired ceramic (LTCC), direct-coupled cavity waveguide bandpass filter (C_DWB)

I. INTRODUCTION

The electromagnetic (EM) spectrum is becoming more crowded, and it is densely populated with various wireless signals and parasitic interferers in connection with communication and sensing services. Increasingly sophisticated radio-frequency (RF), microwave, and millimeter-wave filters are required to enable the selection and/or rejection of specific frequency channels. Compact passband filters with good performance are highly demanded in communication [8]. New techniques and solutions for designing the compact microwave cavity and waveguide filters are discovered and explored to improve the performance and to reduce the filter size [4]. The papers are reviewed on the basis of quality defining parameters of filters relative insertion loss, quality factor, size and cost of microwave resonators made by different techniques as shown in figure 1. The choice of dielectric substrate is also critical to quality factor as loss tangent characteristics are different from one material to another [3]. When high selectivity is required dielectric resonator or metallic waveguide is preferred. The recent widely studied SIW technology is able to fill the technological gap between microstrip or stripline (planar type) and dielectric resonator or metallic waveguide (non-planar type), since it combines the best parts of both and offers high-quality factors that are close to those of non-planar structures with the size- and cost related advantages of printed planar circuits [1]-[3].

Asmita Mary Soreng, Department of Electronics and Telecommunication Engineering, M.E. Scholar, Jabalpur Engineering College, Jabalpur, India.

Dr. Agya Mishra, Department of Electronics and Telecommunication Engineering, Associate Professor, Jabalpur Engineering College, Jabalpur, India.

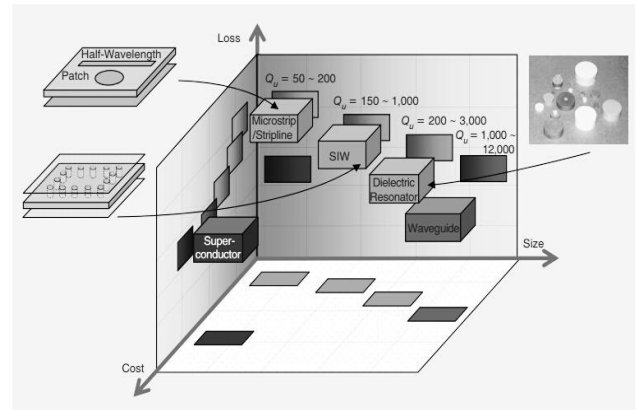

Figure 1: The relative insertion loss, size, and cost of various RF resonators [2].

II. CONCEPT OF CAVITY FILTERS

Cavity filters are the basic circuitry behind a duplexer and are sharply tuned resonant circuit that allow only certain frequencies to pass. Generically, filter of this kind are known as notch filters. Physically a cavity filter is a resonator inside a conducting "box" with coupling loops at the input and output. Still widely used in the 40 MHz to 960 MHz frequency range. Higher Q quality factor, as well as increased performance stability at closely spaced (down to 75 kHz) frequencies, can be achieved by increasing the internal volume of the filter cavities. Physical length of conventional cavity filters can vary from over 82 in the 40 MHz range, down to under 11 in the 900 MHz range. In the microwave range (1000 MHz (or 1 GHz) and higher), cavity filters become more practical in terms of size and a significantly higher quality factor than lumped element resonators and filters [2]. Cavities are often grouped in series with each other to increase filter effectiveness by making the pass band deeper with respect to surrounding frequencies. This can be very useful when ham repeaters are situated very close to other spectrum users such as pager whose unwanted signals can interfere with the ham equipment. Cavity filter are a very effective way to create a notch at the repeater frequencies. Cavity Filters are known for low insertion loss and higher power handling ability.

The filters based on cavity resonators have the advantages of low insertion loss and high power handling capability compared to the filters based on lumped-element LC resonators or planar resonators. Cavity resonator filters are widely used in the wireless and satellite applications [1].

There are different technologies for implementing the cavity resonators, including rectangular/circular waveguide resonator, coaxial resonator, and dielectric resonator [3]. Rectangular/circular waveguide resonators are rectangular/circular waveguides with both ends terminated in a short circuit. Similarly, a section of coaxial transmission line can be short circuited at both ends to form a coaxial resonator.

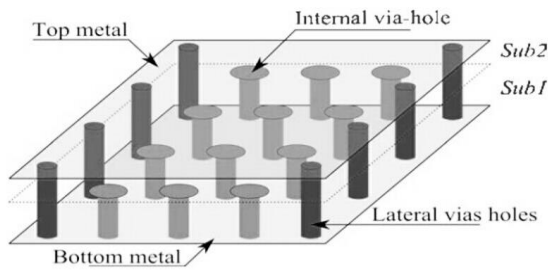

Figure 2: Topology of Slow-Wave SIW Technology [3].

The concept of dielectric resonator filter was first introduced in 1960s. At that time, the dielectric resonator filters were not able to be used in applications due to the poor thermal stability of dielectric material. Advances in decreasing the temperature drift of dielectric material lead to the practical use of dielectric resonator filters. A single dielectric resonator contains the metal enclosure operating below cut-off, a dielectric puck and a support. It is difficult to calculate the resonant frequency, field distribution in dielectric resonators directly. Methods like mode matching technique [1,8], finite-element analysis, and integral equation technique [1] are applied for calculations. Electromagnetic (EM) simulation software, such as HFSS, can be used in calculating the resonant frequency and field distribution in dielectric resonator [1].

A dielectric resonator filter usually consists of a number of resonator cavities separated by irises to achieve inter resonator couplings. Different methods have been developed to achieve the coupling between resonators in DRF including opening irises, coupling screws, coupling loops, and notches in the wall [3,8].

Overall, dielectric resonator filters have the advantages of high power handling capability and low insertion loss. The main drawback of dielectric resonator filters is the spurious performance. An approach of mixing coaxial cavity resonators and dielectric resonators together is used to improve the spurious performance. Also by using a cascade connection of coaxial cavity filter and dielectric resonator filter, we can also improve the spurious performance. This method however will increase the overall size of the filter and increase the insertion loss.

III. WAVEGUIDE FILTERS

A waveguide filter is an electronic filter that is constructed with waveguide technology. Waveguides are hollow metal tubes inside which an electromagnetic wave may be transmitted. Filters are devices used to allow signals at some frequencies to pass (the passband), while others are rejected (the stopband).

A particular feature of waveguide filter design concerns the mode of transmission. Systems based on pairs of conducting wires and similar technologies have only one mode of transmission. In waveguide systems, any number of modes are possible. This can be both a disadvantage, as spurious modes frequently cause problems, and an advantage, as a dual-mode design can be much smaller than the equivalent waveguide single mode design. The chief advantages of waveguide filters over other technologies are their ability to handle high power and their low loss. The chief disadvantages are their bulk and cost when compared with technologies such as microstrip filters.

There is a wide array of different types of waveguide filters. Many of them consist of a chain of coupled resonators of some kind that can be modelled as a ladder network of LC circuits [4]. One of the most common types consists of a number of coupled resonant cavities. However, current trends in the development of RF, microwave and millimeter-wave circuits and systems including antennas are being oriented towards the low-cost and high-density integration of front-end circuits and radiating components and elements. This is now mainly driven by the invention and development of the concept of Substrate Integrated Circuits (SICs), in particular, the substrate integrated waveguide (SIW) [1-4], which allows for the design of usually three-dimensional waveguide circuits and antennas in planar form, thus making possible a complete integration in a single fabrication process of planar and non-planar circuits made of a single substrate.

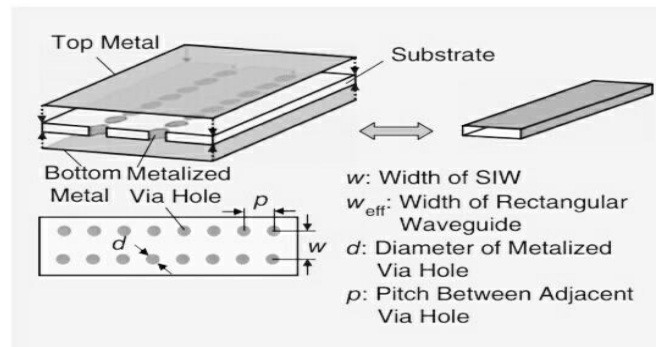

Figure 3: An SIW and its equivalent rectangular waveguide [2].

Power dividers, couplers, filters, antennas, oscillators and other passive and active circuits with this kind of integration platform have been designed and demonstrated. Transitions between the SIW and other planar transmission lines have also been studied and successfully used in practical applications. The performance of the developed components has confirmed the effectiveness and superiority of this new method, which can be used at low cost and for mass production.

IV. EXISTING TECHNOLOGIES

A. Mode Matching Technique For Modeling SIW Discontinuities

In SIW filter designs, periodic circular via holes are not used. Instead, metalized slots are used. Only at cavity corners, slots cut off the conductive walls, where the vertical currents are actually almost vanished. The loss usually comes from two mechanisms, namely imperfect conductor wall and dielectric dissipation loss.

The attenuation constants related to imperfect conductors and dielectric loss in rectangular waveguide, are, respectively [1],

$$\alpha_c = \frac{2R_m}{bz'_0 \left(1 - \frac{k_c^2}{k_0^2}\right)^{1/2}} \times \left[\left(1 + \frac{b}{a}\right) \frac{k_c^2}{k_0^2} + \frac{b}{a} \left(\frac{1}{2} - \frac{k_c^2}{k_0^2}\right) \left(\frac{ab}{a^2 + b^2}\right) \right]$$

$$\alpha_d = \frac{k_0'^2 \tan \delta_l}{2\beta'_{l0}} \quad (1)$$

Where

- R_m is the surface resistance
- $k_0 = k_0 \sqrt{\epsilon_r}$ is the wave number in the dielectric
- $kc = \pi/a$ is the cut off wave number
- β_{10} is the phase constant
- Z_0 is the intrinsic wave impedance of the dielectric medium
- $\tan \delta_1$ is the loss tangent of the dielectric material
- a and b are the SIW guide width and thickness, respectively.

The unloaded quality factor of a half wavelength cavity is,

$$Q_u = \frac{\beta}{2(\alpha_c + \alpha_d)} = \frac{Q_c Q_d}{(Q_c + Q_d)} \quad (2)$$

Where

$$Q_c = \frac{\beta}{2\alpha_c} \text{ and } Q_d = \frac{\beta}{2\alpha_d} \quad (3)$$

The solutions of the S parameters to the step-type waveguide discontinuity (junction) and waveguide bifurcation have to be found, which are critical for the modeling and synthesis of SIW filter structures. A single waveguide step discontinuity and an infinitely long waveguide bifurcation are shown in Figure 4. Let us suppose that an incident H_{10} wave is injected from left into waveguide "a". Forward- and backward scattering happens at the discontinuity. To meet the boundary condition, higher modes are produced in the vicinity of the discontinuity. In the case of SIW structures where the side walls may be synthesized with two arrays of periodic metallic posts, the guided-waves may be simply formulated by TE modes as TM modes are forbidden to propagation along such structures. This is because the side walls do not allow the flowing of current in the propagation direction, which is different from the conventional rectangular waveguide.

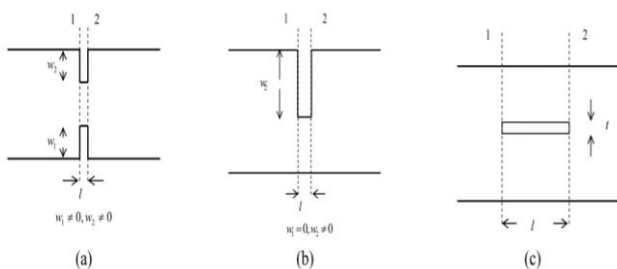

Figure 4: Top view: A pair of inductive discontinuities employed as planar filter coupling parts in rectangular waveguide. (a) Symmetric iris. (b) Asymmetric irises. (c) Centrally located bifurcation (axial strip) [1].

The scattering matrix representation of the waveguide with a single step or bifurcation can be obtained by the technique of mode matching. In the situation of single mode propagation, the incident H_{10} wave from the left is scattered at junction 1. In practice, the wave is often evanescent in the portion between junction 1 and junction 2. When the waveguide junction and the waveguide portion between junction 1 and junction 2 are represented by the scattering matrix (or ABCD matrix), the overall scattering properties can be represented as the multiplicity of three ABCD matrices. The Wexler model is adopted for calculating the discontinuities [1].

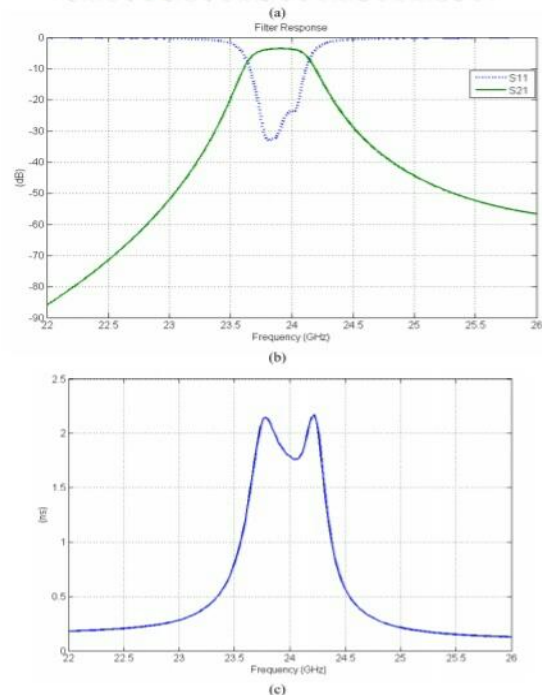
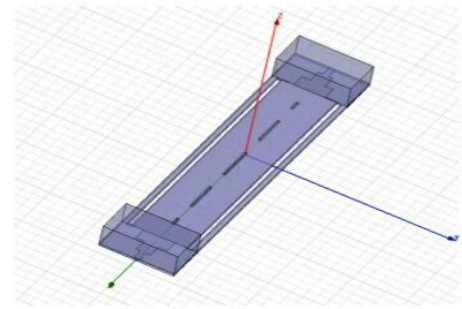

Figure 5: Metal insert filter. (a) HFSS model. (b) Filter response in HFSS. (c) Time delay [1].

B. Insertion Loss Method

The insertion loss method allows a high degree of control over the pass-band amplitude, stop-band amplitude and phase characteristics, with a systematic way to synthesize a desired response. Hence, necessary design trade-offs can be evaluated to meet the application requirements. The Chebyshev response fulfills a requirement for the sharpest cut-off. The insertion loss method hence allows filter performance to be improved in a simple and direct manner, however, at the expense of a higher-order filter. The order of the filter is usually equal to the number of relative elements. The initial design of microwave filters involves a prototype low-pass design through frequency transformations, element normalizations and the realization into microwave transmission line equivalents. Consequently, a physically realizable network is synthesized that will give the desired insertion loss versus frequency characteristics.

This method consists of the following steps [4]:

- design of a prototype low-pass filter with the desired pass-band characteristics
- transformations of the prototype network to the bandpass type filter with the specified center and band-edge frequencies
- realisation of the network in microwave from using sections of microwave transmission lines whose reactances correspond to those of distributed circuit elements.

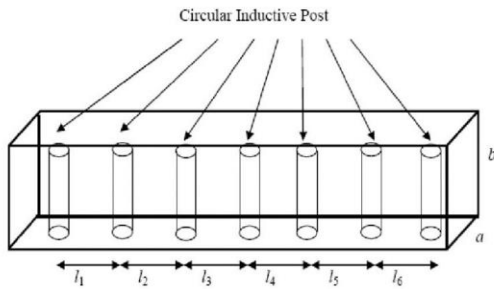

Figure 6: Geometry of a C_DWB filter with spacing l between irises, waveguide dimensions a and b [4].

C. A 3-Pole Filter

In this method, three-pole filters using via walls for 60GHz WLAN narrowband (~1GHz) applications that consist of three coupled cavity resonators(Cavity1, Cavity2, Cavity3 in Figure 7) have been designed and fabricated. The 3-pole band pass filter based on a Chebyshev lowpass prototype filter is developed for a center frequency of 60 GHz, < 3 dB insertion loss, 0.1 dB in band ripple and 1.67 % fractional bandwidth. To meet design specifications, the cavity height was increased to 0.5 mm (five substrate layers) to achieve a higher Q_u and consequently to obtain narrower bandwidth. The cavity resonator with 0.5mm height has been fabricated in LTCC and measured. The comparison between the simulation and the measurement is done. An insertion loss of 1.24 dB at the center frequency of 59.2 GHz and a narrow bandwidth of 1.35 % (~0.8 GHz) has been measured. The theoretical Q_u yields 426 and it is very close to the simulated Q_u of 424 from a weakly coupled cavity in HFSS. After verifying the experimental performance of a single cavity resonator, the external coupling and the inter resonator coupling are considered for the 3-pole filter design [9].

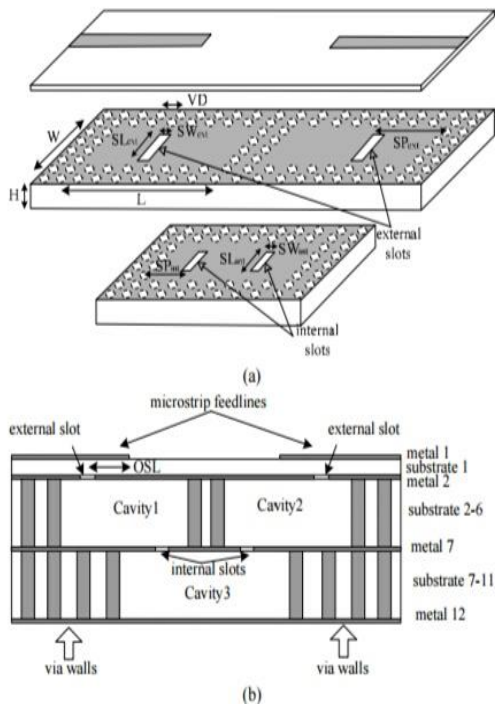

Figure 7: LTCC 3-pole cavity band pass filter employing slot excitation with an open stub: (a) 3-D overview, (b) side view of the proposed filter [9].

The resonant frequency of T_{mnl} is obtained by:

$$f_{res} = \frac{c}{2\pi\sqrt{\epsilon_r}} \sqrt{\left(\frac{m\pi}{L}\right)^2 + \left(\frac{n\pi}{H}\right)^2 + \left(\frac{l\pi}{W}\right)^2} \tag{4}$$

where f_{res} is the resonant frequency, c the speed of light, ϵ_r the dielectric constant, L the length of cavity, W the width of cavity, and H the height of the cavity.

In the case of low external coupling, the unloaded Q , Q_u , is controlled by three loss mechanisms and defined by

$$Q_u = \left(\frac{1}{Q_{cond}} + \frac{1}{Q_{dielec}} + \frac{1}{Q_{rad}} \right)^{-1} \tag{5}$$

The leakage (radiation) loss can be negligible as mentioned above and the individual quantity of two other quality factors can be obtained from

$$Q_{cond} = \frac{(kWL)^3 H \eta}{2\pi^2 R_m (2W^3 H + 2L^3 H + W^3 L + L^3 W)} \tag{6}$$

where k is the wave number in the resonator ($(2\pi f_{res}(\epsilon_r)^{1/2})/c$), R_m is the surface resistance of the cavity ground planes ($(\pi f_{res} \mu / \sigma)^{1/2}$), η is the wave impedance of the LTCC resonator filling, L, W, H the length, width, and height of the cavity resonator, respectively and

$$Q_{dielec} = \frac{1}{\tan(\delta)} \tag{7}$$

where $\tan\delta$ is the loss tangent ($=0.0015$) of the LTCC substrate.

D. Mode Matching Simulation For Micromachined Microwave Cavity Resonator

It involves the derivation of a prototype network in lumped elements, which is then related to the distributed filter geometry through synthesis using mode matching simulations. Simulations were carried out using an in-house developed implementation of a mode matching algorithm. In this design process a Chebyshev polynomial to specify our filter transfer function for a chosen number of poles is used. From here, we compute the lumped-component values for a low-pass ladder prototype circuit, after which we perform a frequency transformation to shift the response to that of a band-pass filter. For a practically realisable band-pass filter, it is convenient to work with identical resonators. In our case, this means that the cavities of the micro-machined filter will be of equal size and shape. For this reason we transform our design to a ladder network with identical resonant circuits and impedance inverters.

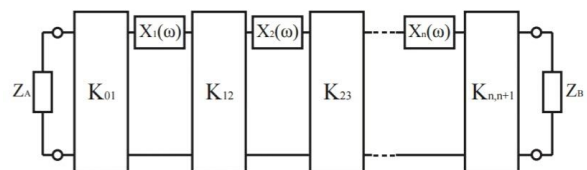

Figure 8: Band-pass ladder-type prototype circuit with identical resonators and impedance inverters [8].

Here, $X_1(\omega), X_2(\omega), \dots, X_n(\omega)$ represent the cavity resonators. The impedance inverters K_{01} and $K_{n,n+1}$ are the ports of the filter and the impedance inverters between resonators are the coupling irises between the cavities. For lumped components, the computed filter response would be exact. However, for microwave filters, we cannot realise lumped elements, and so we use the calculated values as a starting point to design distributed components [8].

Regarding the ladder network, we wish to have our resonators' resonant frequency at the center frequency of the filter.

$$f_r = \frac{c}{\sqrt{\epsilon_r \mu_r} \sqrt{2a}}, \quad (8)$$

From simulated S-parameters, we extract the value of the loaded quality factor Q_l using

$$Q_l = \frac{f_r}{f_2 - f_1}, \quad (9)$$

with f_2 and f_1 the upper and lower -3 dB points of the filter transmission coefficient.

E. Numerical Calibration Technique

Direct-coupled waveguide resonator filters, of which waveguide cavities are cascaded by coupling iris on the common wall, can easily be made compatible with SIW technology. An inductive iris is preferred for the realization of coupling in SIW filters because it has a better stopband performance with respect to an inductive post. The generalized immittance inverter should be used for the parameter extraction of input/output couplings, because different types of transmission lines are used on the two sides of immittance inverter. The Q_u can be calculated from the measured S-parameters as

$$Q_u = \frac{Q_l}{1 - |S_{21}|}, \quad (10)$$

where

$$Q_l = \frac{f_0}{\Delta f_{3\text{ dB}}}. \quad (11)$$

Numerical calibration techniques such as TRL, whose procedure is described in Figure 9, present an efficient method for the accurate parameter extraction of SIW discontinuities. These numerical calibration procedures, similar to the well-established experimental calibration techniques, are used to calibrate out port or connection discontinuity effects between the periodic SIW structures and reference lines. Potential numerical errors and theoretical

modal approximations in the simulation could lead to serious problems in the parameter extractions for equivalent circuit models from the field computations. For typical parameter extractions, the reference lines may be set up in the form of a waveguide structure or microstrip line. This procedure is absolutely necessary when an accurate and one-pass design is anticipated.

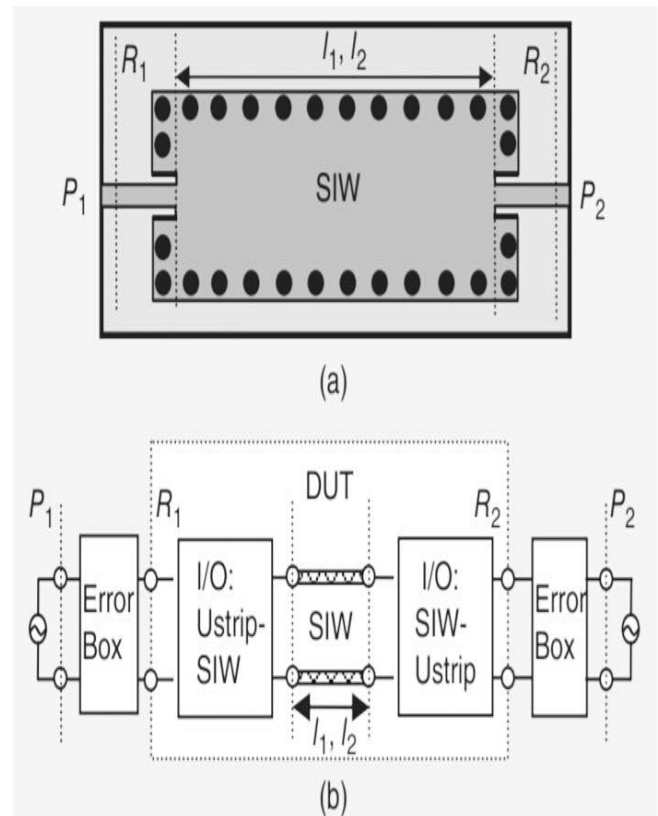

Figure 9: Block diagrams of numerical TRL calibration procedure for input/output structure (a) Input P1/output and (b) DUT [2].

The fifth-order direct-coupled SIW cavity filter with a center frequency of 10 GHz and 10% frequency bandwidth is designed and manufactured on RT/Duroid 5870. The measurement results shows a wide stopband from 11 to 18 GHz below -30 dB [2].

V. COMPARISON OF EXISTING TECHNIQUES OF MICROWAVE FILTERS

The comparison table 1 below illustrates the design techniques of existing microwave cavity and waveguide filters where the frequency range, various measuring parameters and the techniques used to design the existing filters are critically reviewed.

From the table 1 it can be concluded that the cavity filter on substrate integrated waveguide (SIW) has provided an alternative for the integration of high-performance and low cost passive components. Several topologies have been proposed to design SIW cavity filters [1-3]. LTCC technology may present an effective method to miniaturize SIW filters with good Q_u values [9]

Table 1: Comparison Of Existing Techniques Of Microwave Filters

Sr. No.	Reference Paper	Technique/Method	Frequency Range	Measuring Parameters & Values	Advantages	Limitations
1	Substrate-Integrated Waveguide Filters for Low-Cost High-Density RF and Microwave Circuit Integration[1]	Direct-Coupled Cavity Bandpass Filters With Chebyshev Response (Mode Matching for SIW)	Passband at near 24 GHz (K-band)	Insertion loss = 3.4 dB Return loss = 17 dB Bandwidth = 440 Mhz (1.8%) $Q_u = 289 \sim 1772$	The mass-fabrication of such SIW filters can be made easy while maintaining a very low cost	The main limitation of SIW used for filter design is the dielectric loss which is relatively high
2	Substrate Integrated Waveguide Filters[2]	Direct-Coupled SIW Cavity Resonator Filters (Numerical Calibration Technique)	Center frequency = 10 GHz	$Q_u = 150 \sim 1000$ Wide stopband from 11 to 18 GHz below -30 dB 10% frequency bandwidth	Size and Cost effective High quality factor	Hybrid integration on SIW platform increases challenges in effectively designing SIW filter
3	Compact Slow-Wave Substrate Integrated Waveguide Cavity Filter[3]	Blind metalized via-holes for slow wave effect	Centre frequency = 11 GHz	Insertion loss = 3.2 dB Return loss is better than -12 dB in the passband Bandwidth = 900 MHz	The filter surface area is more than three times smaller compared to classical SIW	Further works including a lower loss top substrate, or air-filled cavities can be achieved in order to reduce the insertion loss
4	Design of Microwave Direct-Coupled Cavity Waveguide Filter VSAT Communication at C-Band [4]	Insertion loss method	Operating frequency of 3.902 GHz	Lower and upper cut-off frequencies of 3.625 GHz and 4.2 GHz, respectively Return loss better than -20 dB in the passband stopband Insertion loss of smaller than -30 dB	Has minimum losses at high frequencies especially at specified frequency of operation	
5	Micromachined Thick Mesh Filters For Millimeter-Wave and Terahertz Applications [5]	Based on a thick mesh filter structure and fabricated using SU-8 micromachining techniques	Resonant frequency at 300 GHz	Loaded Q-factor = 16.3 Insertion loss = 0.98 dB	These thick mesh filters can potentially be used for sensing and material characterization at millimeter-wave and terahertz frequencies	Loaded Q-factor is generally low
6	High-Q Tunable Microwave Cavity Resonators and Filters[6]	Using SOI-based RF MEMS Tuners	Frequency range of 3.04 - 4.71 GHz	$Q_u = 300 \sim 650$ Bandwidth = 0.7% insertion loss = 3.55-2.38 dB	High quality factor	Low-temperature bonding techniques will result in even higher quality factors and reduced RF losses

7	Microwave Cavity Bandpass filter[7]	Chebyshev bandpass filter	Frequency range of 25 GHz-60GHz	Q-factor=108 Insertion loss = 1.46 dB	Low insertion loss High frequency selectivity	
8	Micromachined microwave cavity resonator filters for 5G [8]	Mode matching technique	Frequency range of 20 GHz-100GHz Center frequency=27.7 GHz	BW=900 MHz Separation=300 MHz Isolation=40-50 dB Data rate=212 Mbps	Low insertion loss High quality factor Lightweight Easy to integrate	Using four poles, we cannot design a filter that meets all the 5G specifications as extrapolated from a 3G/4G case
9	Low Loss LTCC Cavity Filters Using System-on-Package Technology [9]	System-on-Package Technology	Frequency range of 55-60 GHz	Insertion loss = 2.14 dB Return loss> 20.6 dB Rejection>16.4 dB Passband(0.89 GHz) Bandwidth 3 Db of 1.38% (~0.9 GHz)	lowest loss is reported for a LTCC 3D integrated narrowband filter at 60 GHz	

VI. CONCLUSION

In this review, various microwave cavity and waveguide filters and their needs in various application is critically reviewed and from these reference papers we conclude that the compact slow wave substrate integrated waveguide filter is a fifth order cavity filter centered at 11 GHz exhibiting a bandwidth of 900 MHz. It achieves 3.2 dB insertion loss and return loss is better than -12dB in the passband [3]. This prototype demonstrated an area reduction of 70% compared to similar SIW cavity filters. Overall reduction in physical volume is demanding in modern communication system while still maintaining the good performance in the specified frequency range. SIW technology has proven to be a serious and successful alternative for a wide range of RF and millimeter-wave filters in wireless sensing and communication systems. SIW filters will continue to attract more interest from both academia and industry for their flexibility and versatility. This review will be certainly beneficial for researchers of microwave filter design.

REFERENCES

[1] Yu (Freeman) Tang, Ke Wu, and Nazih Khad daj Mallat,, "Development of Substrate-Integrated Waveguide Filters for Low-Cost High-Density RF and Microwave Circuit Integration: Direct-Coupled Cavity Bandpass Filters With Chebyshev Response", IEEE Access, Volume 3, 2015.

[2] Xiao-Ping Chen and Ke Wu, "Substrate Integrated Waveguide Filter", IEEE Microwave magazine July/August 2014.

[3] Matthieu Bertrand, Zhanhao Liu, Emmanuel Pistono, Darine Kaddourt, Philippe Ferrari, "A Compact Slow-Wave Substrate Integrated Waveguide Cavity Filter", IEEE 2015.

[4] Mazlina Esa, Rengiah Sinnathamby, Mohd Fairus Mohd YusoffandNoor Asniza Murad, "Design of Microwave Direct-Coupled Cavity Waveguide Filter for VSAT Communication at C-Band Using MathCAD Software", IEEE International RF and Microwave Conference, 2006.

[5] Yi Wang, Bin Yang, Yingtao Tian, Robert S. Donnan, and Michael J. Lancaster, "Micromachined Thick Mesh Filters for Millimeter-Wave and Terahertz Applications", IEEE Transactions on Terahertz Science and Technology , Volume: 4, Issue: 2, March 2014.

[6] Xiaoguang Liu, Linda P. B. Katehi, Fellow, William J. Chappell, and Dimitrios Peroulis, "High-Q Tunable Microwave Cavity Resonators and Filters Using SOI-Based RF MEMS Tuners", IEEE Journal of Microelectromechanical Systems, Vol. 19, no. 4, August 2010.

[7] Ashna Shaiba, Dr. Agya mishra, "Design Of Microwave Cavity Bandpass Filter From 25 GHz To 60GHz", IJERA- International Journal of Engineering Research and Application , VOL. 07, Issue 9(Part- 6), September 2017.

[8] R. van Kemenade, A. B. Smolders and B. P. de Hon, "Micromachined Microwave Cavity Resonator Filters for 5G: a Feasibility Study", IEEE 2015. M. Young, *The Technical Writers Handbook*. Mill Valley, CA: University Science, 1989.

[9] Jong-Hoon Lee, IEEE, Stephane Pinel, Member, IEEE, John Papapolymerou, Senior Member, IEEE, Joy Laskar, Senior member, IEEE and Manos M. Tentzeris, senior member, IEEE, "Low Loss LTCC Cavity Filters Using System-On Package Technology At 60 GHz", IEEE Transactions On Microwave Theory And Techniques, SEP. 2011.

Asmita Mary Soreng, Department of Electronics and Telecommunication Engineering, M.E. Scholar, Jabalpur Engineering College, Jabalpur, India.

Dr. Agya Mishra, Department of Electronics and Telecommunication Engineering, Associate Professor, Jabalpur Engineering College, Jabalpur, India.