

GSM Controlled Automatic Irrigation System

Shivam Mishra, Anubhav Srivastava, Vijay Kumar Mall

Abstract— Agriculture plays a very important role in the development of food production in all the countries. As the population in this world is increasing day by day and the requirement of the food is also increasing in proportion. So, the agriculture sector should also be made precise as to maintain the demand and supply chain. In some of the countries, agriculture is totally dependent on the monsoon which is not the adequate source of water. To fulfill the water requirement of the crops, irrigation is used. In this system, the water is provided to the plants according to the soil type. As the water is provided according to the requirement of the crops, ultimately this will help in conservation of the water.

Advancement in technology always gives a chance to make the work simpler and to reduce the risks. Through this paper we are improving the throughput and average delay in sending or receiving the data so as to bring precision in the field of agriculture. This system aims at saving the time as well as solves the problem of constant attentiveness. The solutions to many problems can be provided by the application of embedded and micro controller systems. This system is incorporated with GSM module which gives the updates about the water requirement to the farmer by sending a prior generated message. The soil moisture sensor senses the water requirement and hence sends the data to the micro controller which further controls the water system. The previous systems have been studied in depth so as to improve the performance efficiency of this prototype from its predecessors.

Index Terms— GSM, Moisture Sensor, Pump Motor, Microcontroller.

I. INTRODUCTION

The major source of income in many countries is agriculture and 40% to 60% people depend on the agriculture for their livelihood. The water level is decreasing day by day. The water scarcity is the major problem which is faced by many countries and as the agriculture demands plenty of water; it also gets affected due to water scarcity. The GSM controlled automatic irrigation system senses the moisture level into the soil and then operates the water system to irrigate the fields according to the requirement. The advantage of this system is that it helps in using the water judiciously and hence helps in saving the water [4][2].

Tensiometric and Volumetric techniques are used by the soil moisture based irrigation control [3]. The quantities are related through a curve known as soil water characteristic curve which is specific to a soil type. The sensors which are used demands maintenance to give proper efficiency. This prototype waters the field automatically without human attention and automatically sends a prior generated message

to the farmer for giving the updates regarding water level in the field and the data about the water system.

The expeditious enhancement in the production of food technology is very important to fulfill the steadily increasing demands of the food necessities. The only source which can provide this is agriculture [5]. The economy and development of the country depend on the agriculture sector, like India. The farmers are continuously demanding the cost-effective, non-destructive and green methods for measuring the important parameters which assist in growing a good quality crop and helps in analyzing those parameters and works accordingly. To grow crops, the farmers require water and for this they use irrigation. The most important parameter in determining the quality of the crops is the moisture content in the soil. Due to advancement in the irrigation technologies, dependencies on rain have reduced. All these systems or technologies are driven with the help of electrical power. Much advancement has been done in the field of agriculture and this had really helped in the quality as well as the production of crops. Researchers and engineers are continuously working on several experiments to help the farmers by bringing new technologies into the field of agriculture.

In this paper, a design of GSM controlled automatic irrigation system is presented. This system is based on micro controller and embedded technology. Soil moisture sensor is used to sense the moisture or humidity within the soil continuously and provides the information to the farmer through the phone without visiting the fields. If the water level in the soil is equivalent to the required amount then the water pump will be OFF otherwise it will be ON until the water level reaches the required amount. This saves the crops from being over irrigated and also helps in saving the water resources and the energy. Also, the farmer need not visit the fields frequently as the information is sent to him by the GSM module. Also, the farmer can control the process with the help of the cellular phone by sending signals to the GSM module which will further give commands to the microcontroller to carry out the tasks as given by the farmer. This system can be installed and configured very easily. It is very useful in greenhouse vegetable production as it is the efficient method of irrigation and this tool helps in controlling the soil moisture within the highly specialized crops.

II. 8051 MICROCONTROLLER

The 8051 microcontroller was developed in the year 1980 by Intel for several applications in the embedded system. This microcontroller belongs to the Intel MCS-51 family which is an internally Harvard architecture, CISC instruction set, single chip microcontroller. During the 1980s and early 1990s, it became very popular due to its applications. Originally, NMOS technology was used to develop this microcontroller. But later less power consuming technology

Shivam Mishra, B.Tech, Department of Electronics and Communication, K.I.E.T., Ghaziabad. Phone No. — +91-9582346836
Anubhav Srivastava, B.Tech, Department of Electronics and Communication, K.I.E.T., Ghaziabad. Phone No. — +91-8707605816
Vijay Kumar Mall, B.Tech, Department of Electronics and Communication, K.I.E.T., Ghaziabad. Phone No. — +91-7217406905

like CMOS was used to develop the microcontroller. For instruction and data, the 8-bit word is used. 8051 assembly language can be used to program all of the above architecture; as all these share some common features along with their own specialized features [1].

The features of the 8051 microcontroller are as follows:-

1. It has 2 external and 3 internal interrupts.
2. It has two 16-bit timers
3. It is equipped with four 8-bit ports
4. It has a 16-bit program counter and data pointer.
5. It has 32 general purpose registers each of 8-bits
6. It has 16-bit address bus
7. It has 8-bit data bus
8. It has 128 user defined software flags
9. It has 4 register banks
10. It has 128 bytes of chip data memory.
11. It has 64 kB of on-chip memory.

III. PIN DIAGRAM

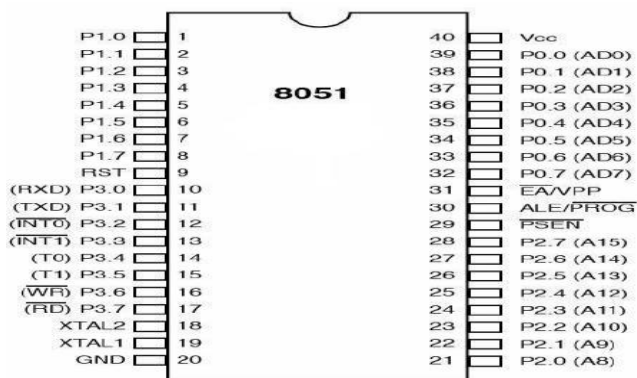

Fig.1. Pin diagram of 8051 microcontroller

IV. BLOCK DIAGRAM

The block diagram explains the working of the whole system and displays the functionality of each component.

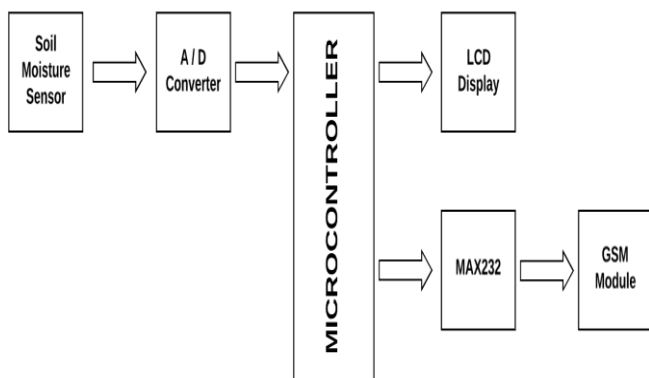

Fig.2. Block Diagram

All the operational blocks of the block diagram is explained below:-

1. The Soil Moisture Sensor is the very first segment which senses or measures the quantity of moisture level or water level into the soil. It basically gives the analog value. Measuring the soil moisture helps in doing the precision

irrigation, which ultimately helps in growing good quality crops and also enhances the yield.

2. The second segment is the Analog to digital converter which converts the analog value given by the soil moisture sensor to the digital value and this digital value is further used to carry out the task.
3. The LCD (Liquid Crystal Display) module displays the moisture level within the soil and also the status of the irrigation.
4. The GSM module is used to send the prior generated message to the farmer’s cellular phone and also the farmer can control the irrigation from the cellular phone by sending the signals. The MAX232 is a dual transmitter / dual receiver that typically is used to convert the RX, TX, CTS and RTS signals. The MAX232 is used in accordance with the GSM Module (SIM900).

All the above sensors and components are connected to a single entity known as microcontroller which controls all the functions and gives the instructions to all the components to carry out the tasks. The LCD module is a 16x2 alphanumeric display and the GSM module used is the SIM900 module.

V. FUNCTIONAL DIAGRAM

The functional flow diagram shows the flow of signals and data to carry out the whole task within the system. Firstly, the reference value for the water level is set using the normal condition value. The microcontroller checks the water level and if the water level is greater than or equal to the reference value then the water pump is switched OFF. But, when the water level or moisture level within the soil fall and become less than the reference value then the microcontroller sends the signal to switch the water pump ON till the water level become equal to the reference value. The GSM with the help of microcontroller sends the prior generated message to the farmer’s cellular phone and also the farmer can control the process of irrigation by sending the signals from the same cellular phone. The functional diagram is shown below:-

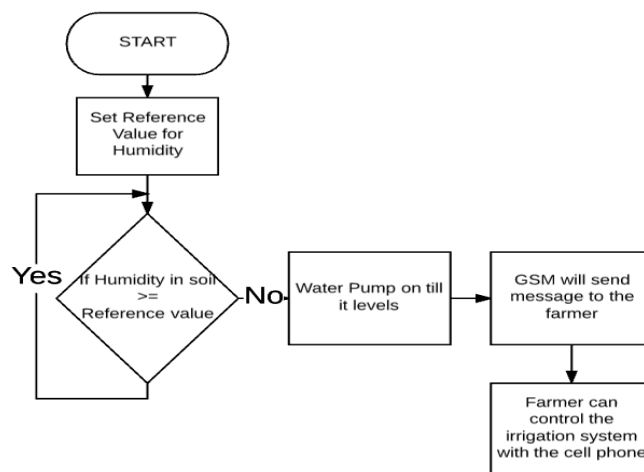

Fig.3. Flow Chart

VI. CIRCUIT DIAGRAM

The circuit diagram shown in the fig.4. Shows the connections of all the modules along with the microcontroller.

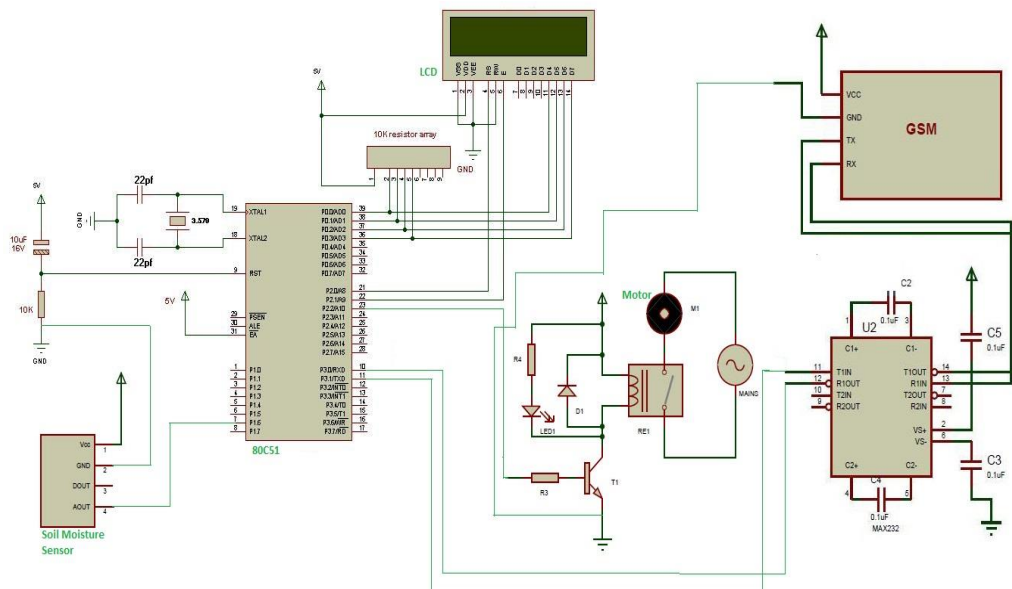

Fig.4. Circuit Diagram

VII. FUTURE DEVELOPMENT

1. In future, this project design can be incorporated with the pH meter so as to estimate the amount of the important ingredients like potassium, sodium and phosphorous. This will help in putting the fertilizers into the field as it can be done according to the requirements of the soil.
2. IOT (Internet of Things) can be used so as to make the process of irrigation more sophisticated. Using IOT, each and every data can be easily seen on the smart phone with the help of specific apps.
3. Some other tools can be improvised within the system so as to predict the weather which will assist in carrying out the tasks in a much better way.

VIII. CONCLUSION

In this paper, we are providing a design which uses the microcontroller in the development of GSM controlled automatic irrigation system which can prevent the wastage of water and also saves the crops from being over-irrigated. This system uses soil moisture sensor to measure the moisture or water level within the soil and hence automatically irrigates the field as required. The GSM module is incorporated within the system which sends the prior generated message to the cellular phone of the farmer and the farmer can control the irrigation from the phone only. As in many countries, the farmers are totally dependent on the manual operated irrigation system which affects the production in the negative direction. So, this system can help those farmers in the irrigation. Also, continuous vigilance is not required as the technology will do its work.

ACKNOWLEDGMENT

We are very grateful to all those who were beside us during the course of making this project. We would like to thank our family and our friends who were always there with us with their constant support and encouragement. We would also like to thank Mr. Vibhav Kumar Sachan who helped us a lot in

making this project. This project is sponsored by Department of Electronics and Communication Engineering, Krishna Institute of Engineering and Technology, Ghaziabad.

REFERENCES

- [1] Muhammad Ali Mazidi, Janice Gillispie Mazidi, "The 8051 microcontroller and embedded systems using assembly and C", 2nd edition, Pearson India.
- [2] S. Darshna, T.Sangavi, Sheena Mohan, A.Soundharya, Sukanya Desikan; Smart Irrigation System; IOSR Journal of Electronics and Communication Engineering (IOSR-JECE), 10[3], 2015.
- [3] Rafael Muñoz-Carpena and Michael D. Dukes, Automatic Irrigation Based on Soil Moisture for Vegetable Crops, IFAS Extension, 2005.
- [4] K.N.Manjula B.Swathi and D.Sree Sandhya, Intelligent Automatic Plant Irrigation System.
- [5] Deweshvree Rane, P. R. Indurkar, D. M. Khatri; Review paper based on automatic irrigation system based on RF module; IJAICT, 1[9], 2015.



Shivam Mishra is a student in B.Tech, in Krishna Institute of Engineering and Technology, Ghaziabad. He has done a lot of project in embedded systems and is also leading a team of enthusiastic engineering students in the college's robotics team. He is a dedicated and compassionate student committed to the field of research. He is the author of this research paper.



Anubhav Srivastava is a student in B.Tech, in Krishna Institute of Engineering and Technology, Ghaziabad. He is working on several projects based on embedded systems. He is the co-author.



Vijay Kumar Mall is a student in B.Tech, in Krishna Institute of Engineering and Technology, Ghaziabad. He is working on several projects based on embedded systems. He is the co-author.