

Simulation Framework for Speech Signal Processing In Wireless Sensor Network

Umesh Kumar, Dr. Neelendra Badal

Abstract— Wireless Sensor Networks (WSN) are framed by an expansive number of arranged detecting hubs. It is fairly unpredictable, or even unfeasible, to show scientifically a WSN and it more often than not prompts distorted examination with restricted certainty. In addition, sending proving grounds assumes an enormous exertion. In this way, reproduction is basic to ponder WSN. A Wireless Sensor Network (WSN) is a disseminated set of sensors sent to cooperate for aggregate detecting and conceivable information handling. A WSN can be utilized to screen natural conduct and basic honesty in an assortment of utilization fields, hence turning into a basic piece of purchaser gadgets of shrewd structures in brilliant urban communities.

The wireless sensor network comprises of a few self-ruling sensor hubs with detecting, preparing and remote correspondence abilities. These sensor hubs are appropriated spatially to screen physical and ecological conditions, for example, temperature, weight, stickiness, vibration, sound, movement or contaminations and agreeably send the detected information to the end client through the system. Essential approach comprises of different reenactment devices in view of various stages. MATLAB/simulink is use to outline and execute of a structure for discourse motion in remote sensor organize. Reproduction is use for outline equipment design of the transmitting hub, recompenses channel and the accepting hub. Here Bluetooth innovation is use to attempt the physical layer correspondence as for various parameter. Bluetooth is a short-go radio connection innovation. The reenactment model is checking utilizing diverse topology under different conditions and gathers the many outcomes.

Index Terms— Wireless sensor network, scalability.

I. INTRODUCTION

A Wireless sensor Network (WSN) commonly comprises of a substantial number of minimal effort, low power, and multifunctional remote sensor hubs with detecting, remote interchanges and calculation capacities. Wireless sensor Network (WSN) comprises of small battery controlled sensor hubs to screen physical or natural conditions, similar to sound, vibration, weight, temperature, movement or poisons at various areas [2]. The nodes need to communicate with each other the and with base station in order to collect and transmit required data. Hence, the routing is considered as a major research challenge in WSNs. In this network, node senses the data from impossibly accessible area and sends their report to the base station also called the sink. The nodes in wireless sensor networks can be mobile or stationary and

deployed in the area through a proper or random deployment mechanism.

A typical sensor is used to sense environmental properties such as temperature, pressure, stress and vibration in the form of electrical signals which are then calibrated to measure the corresponding physical properties [1]. Wireless sensor networks (WSNs) are collections of such sensors deployed to sense variations in, and transmit data through, wireless networks as depicted in Figure 1 [2].

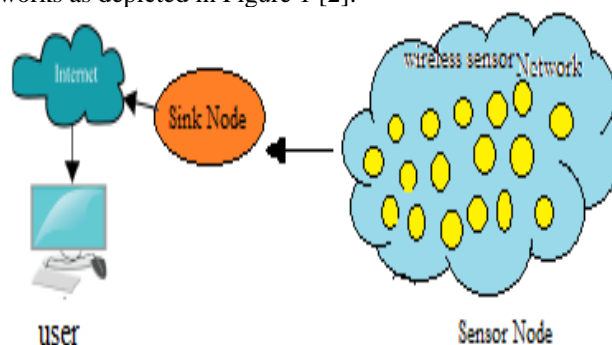

Figure 1 Wireless Sensor Network

Wireless Sensor Networks(WSN) have increased overall consideration as of late because of the advances made in wireless correspondence, data advances and hardware field. WSN is a developing innovation that can be sent in such circumstances where human association is unrealistic like outskirts zone following, foe development or fire discovery framework. A sensor arrange commonly comprises of a considerable measure number of sensor hubs thickly conveyed in an area of intrigue, and at least one information sinks or base stations that are situated inside the detecting locale. A WSN can be characterized as a system of gadgets, signified as hubs, which can detect the earth and convey the data assembled from the checked field (e.g., a range or volume) through remote connections. The information is sent, perhaps by means of various bounces, to a sink (some of the time meant as controller or screen) that can utilize it locally or is associated with different systems (e.g., the Internet) through a portal. The hubs can be stationary or moving. They can know about their area or not. They can be homogeneous or not. Today, remote sensor systems are generally utilized as a part of the business and modern ranges

II. A SMART SENSOR NODE

A smart sensor node is a combination of sensing, processing and communication technologies. Figure 3.4 shows the basic architectural components of a sensor node. The sensing unit senses the change of parameters, signal conditioning circuitry prepares the electrical signals to convert to the digital domain, the sensed analog signal is converted and is used as the input

Umesh Kumar, Department of Computer Science and Engineering Feroze Gandhi Institute of Engineering and Technology, Raebareli, India.

Dr Neelendra Badal, Associate Professor, Department of Computer Science and Engineering, Kamla Nehru Institute of Technology, Sultanpur, India.

to the application algorithms or processing unit, the memory helps processing of tasks and the transceiver is used for communicating with other sensors or the base stations or sinks in WSN [3], see figure 2.

Sensors can monitor vehicular movement, noise levels, lighting conditions, the presence or absence of certain kinds of objects or substances, mechanical stress levels on attached objects, and other properties. Their mechanism may be seismic, magnetic, thermal, visual, infrared, acoustic, or radar. A smart sensor is also capable of self-identification and self-diagnosis. The smart sensors work in one of three ways: by a line of sight to the target (such as visual sensors), by proximity to target (such as seismic sensors), and by propagation like a wave with possible bending (such as acoustic sensors) [4,5].

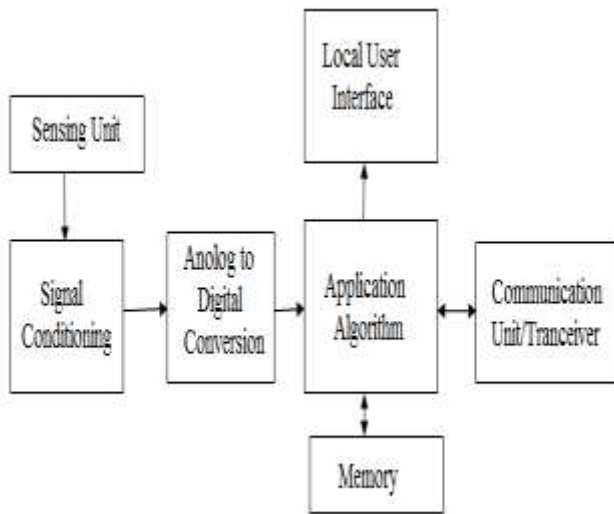

Figure 2 A smart sensor components

Five main parts of sensor node are:

- **The Central Unit:** It is in the form of microprocessor which manages the tasks.
- **Battery:** Is the source of energy
- **A Transceiver:** Interacts with the environment and collects data.
- **Memory:** Used as storage media for storing data or processing data.
- **Communication Module:** It includes transceivers and forwards queries and data to and from central module. Energy efficiency in all parts of sensor network is very crucial for long network lifetime. Nodes in the sensor network cooperate and spread the data processing task and send the processed information to sinks. For reducing the overhead of power supply of each and every node, Radio Frequency Identification (RFID) chips with no batteries are developed.

III. WIRELESS SENSOR NETWORKS: STATE-OF-ART

The advancement of WSNs has led to more accurate monitoring of structural integrity, data collection and analysis of observed data. However, the data collection process is affected by various factors. Different solutions and algorithms have been proposed by researchers to improve the performance of the WSN.

A. Power Management

The sensor nodes are powered by a battery source, and the lifetime of the sensor node is determined by the energy stored in the battery. Hence, the effective use of the available power is a main challenge faced in sensor data collection. An algorithm for selecting the cluster heads for a group of sensors in order to reduce the power consumption is proposed in [3]. The algorithm was based on random head selection where minimum distance between the nodes was tabulated. Then the node with the minimum hopping distance was determined and assigned as the cluster head, which reduces the energy required to hop the data over long distances. An optimizing algorithm for limited buffering and controlled mobile sink is proposed in [4].

B. Data Collection

One of the most important operations of the sensor nodes is the data collection. Different data aggregation techniques have been proposed for efficient data collection. A complete information collection mechanism by deploying an agent in the WSN is proposed in [5]. This agent collaboration provides a means to coordinate with multiple sensor nodes to complete data collection, analysis and distributed fault diagnosis. Different agents are assigned different operations, and they coordinate with each other to complete the entire task, as shown in Figure 3. The model is simulated in a network simulator to verify operation.

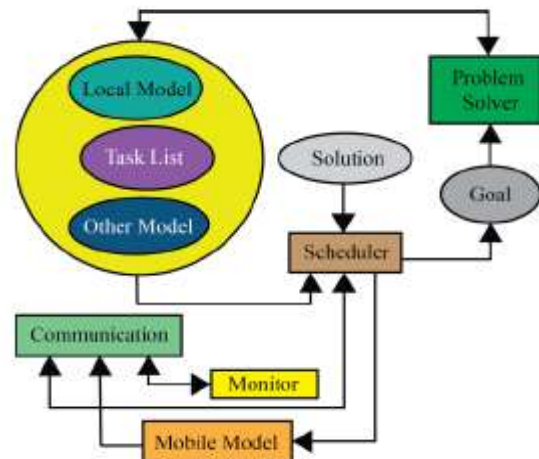

Figure 3 A Typical agent structures

C. Communication Protocols

In order to obtain complete information of the area of interest, a large number of sensor nodes are deployed. When all these sensor nodes try to communicate with the base station or sink, data congestion can occur. A new congestion control mechanism is proposed in [6]. In this mechanism, the buffer in each node is adjusted based on downstream data transmission in order to minimize packet loss. The performance of the algorithm was verified by simulating the model in MATLAB.

IV. MODEL FOR WSN SIMULATION

Together with the development of simulation tools for WSN, their corresponding models have been introduced. The models include new components, not present in classical network simulators, as detailed power and energy consumption models or environment models. This section describes a general component model, derived [5], [6], for

WSN simulation tools. This model is suitable for most of the evaluation tools employed in on-going research on WSN.

A. Network model

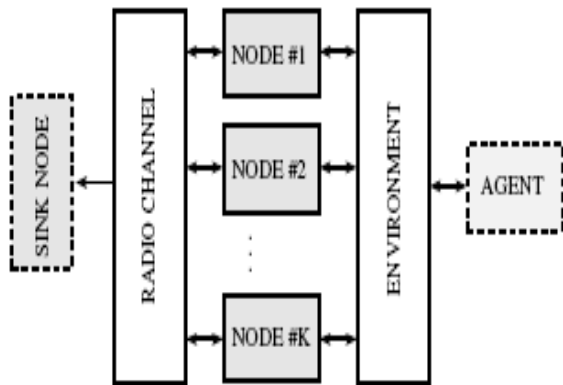

Figure 4 Wireless sensor network model

Figure 4 depicts the general model at a network-wide scale. The following components are considered:

Nodes: Each node is a physical device monitoring a set of physical variables. Nodes communicate with each other via a common radio channel. Internally, a protocol stack controls communications. Unlike general network models, sensor nodes include a second group of components: The physical node tier, which is connected to the environment. Nodes are usually positioned in a two or three dimensional world. An additional “topology” component, not showed in figure 4 may control node coordinates. Depending on the application and deployment scenario, a WSN can contain from a few to several thousands of nodes.

Environment: The main difference between classical and WSN models are the additional “environment” component. This component models the generation and propagation of events that are sensed by the nodes, and trigger sensor actions, i.e. communication among nodes in the network. The events of interest are generally a physical magnitude as sound or seismic waves or temperature.

Radio channel: It characterizes the propagation of radio signals among the nodes in the network. Very detailed models use a “terrain” component, connected to the environment and radio channel components. The terrain component is taken into consideration to compute the propagation as part of the radio channel, and also influences the physical magnitude.

Sink nodes: These are special nodes that, if present, receive data from the net, and process it. They may interrogate sensors about an event of interest. The use of sinks depends on the application and the tests performed by the simulator.

Agents: A generator of events of interest for the nodes. The agent may cause a variation in a physical magnitude, which propagates through the environment and stimulates the sensor. This component is useful when its behavior can be implemented independently from the environment, e.g., a mobile vehicle. Otherwise, the environment itself can generate events.

B. Node model

Node behavior depends on interacting factors that cause cross-layer interdependencies. A convenient way to describe it is to divide a node into abstract tiers, as represented in Figure 5.

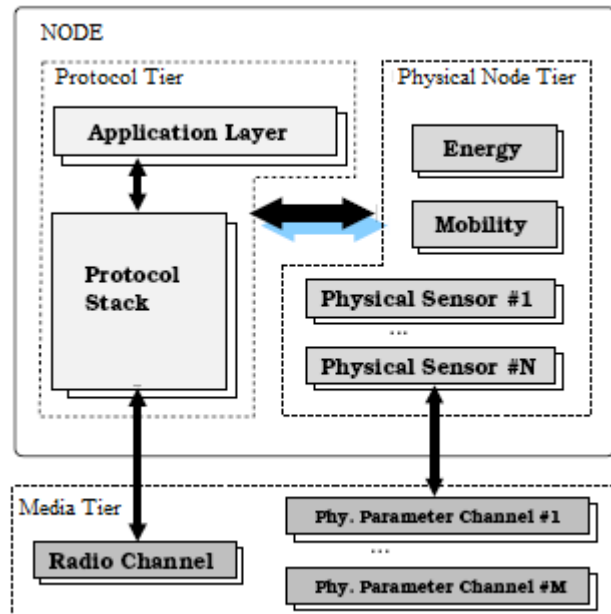

Figure 5 Tier-based node models

- The *Protocol-tier* comprises all the communication protocols. Typically, three layers coexist at this tier: A MAC layer, a routing layer and a specific application layer. Note that the operation of the protocol tier usually depends on the state of the physical tier described below, e.g. a routing layer can consider battery constraints to decide on packet route. Hence, an efficient method to interchange tier information must be developed.
- The *physical-node* tier represents the hardware platform and its effects on the performance of the equipment. Actual composition of this tier may change depending on the specific application. The common elements of this tier are the set of physical sensors, the energy module and the mobility module. Physical Sensors describe the behavior of the monitoring hardware. Energy module simulates power consumption in the component hardware, a critical issue in WSN evaluation. Mobility module controls sensor position.
- The *media-tier* is the link of the node with the “real world”. A node is connected with the environment through: (1) A radio channel, and (2) through one or more physical channels.

V. WSN METHODOLOGY IN MATLAB SIMULINK

The environment in which we build our simulation model was MATLAB. The name MATLAB stands for matrix laboratory. MATLAB, developed by Math Works Inc., is a software package for high performance numerical computation and visualization. The combination of analysis capabilities, flexibility, reliability, and powerful graphics makes MATLAB the premier software package for scientific researchers. MATLAB provides an interactive environment

with hundreds of reliable and accurate built-in mathematical functions. These functions provide solutions to a broad range of mathematical problems including matrix algebra, complex arithmetic, linear systems, differential equations, signal processing, optimization, nonlinear systems, and many other types of scientific computations. The most important feature of MATLAB is its programming capability, which is very easy to learn and to use, and which allows user-developed functions. It also allows access to Fortran algorithms and C codes by means of external interfaces. There are several optional toolboxes written for special applications such as signal processing, control systems design, system identification, statistics, neural networks, fuzzy logic, symbolic computations, and others. MATLAB has been enhanced by the very powerful Simulink program[59]. The simulation results can be put in the MATLAB workspace for post processing and visualization. And because MATLAB and Simulink are integrated, you can simulate, analyze, and revise your models in either environment at any point.

MATLAB Simulink communication block set was used to build a complete WSN system. Simulation procedure includes building the hardware architecture of the transmitting nodes, modeling both the communication channel and the receiving master node architecture. Bluetooth was chosen to undertake the physical layer communication with respect to different channel parameters (i.e., Signal to Noise ratio, Attenuation and Interference). The simulation model was examined using different topologies under various conditions and numerous results were collected.

In order to demonstrate the concepts of the suggested simulation methodology. This network consisted of three sensors (slaves) sending their measured data samples to a master node. In this chapter, MATLAB Simulink communication block set was used to build a complete WSN system. Simulation procedure includes building the hardware architecture of the transmitting nodes, modeling both the communication channel and the receiving master node architecture. Bluetooth was chosen to undertake the physical layer communication with respect to different channel parameters (i.e., Signal to Noise ratio, Attenuation and Interference). The simulation model was examined using different topologies under various conditions and numerous results were collected. Simulink main model of the test system is given in Figure 6.

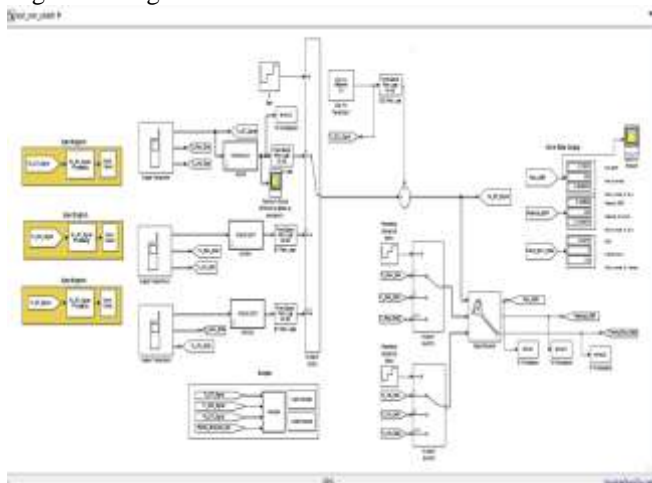

Figure 6 Main Model

VI. RESULTS

In this section we describe the all result under model.

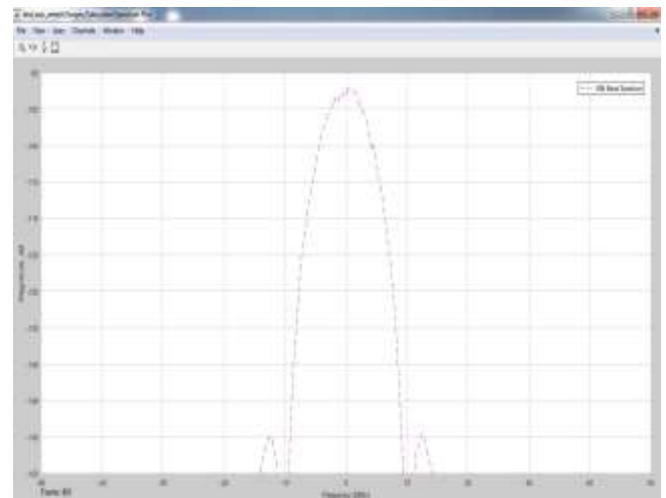

Figure 7 Power Spectrum

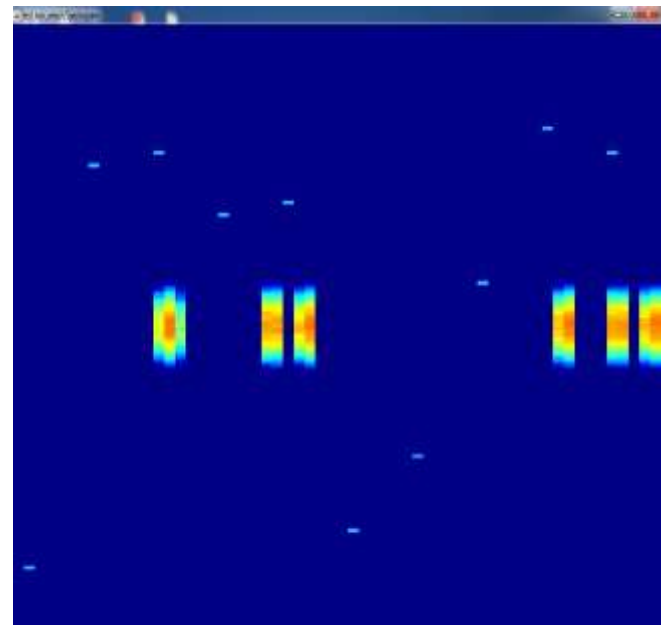

Figure 8 Spectrogram 1

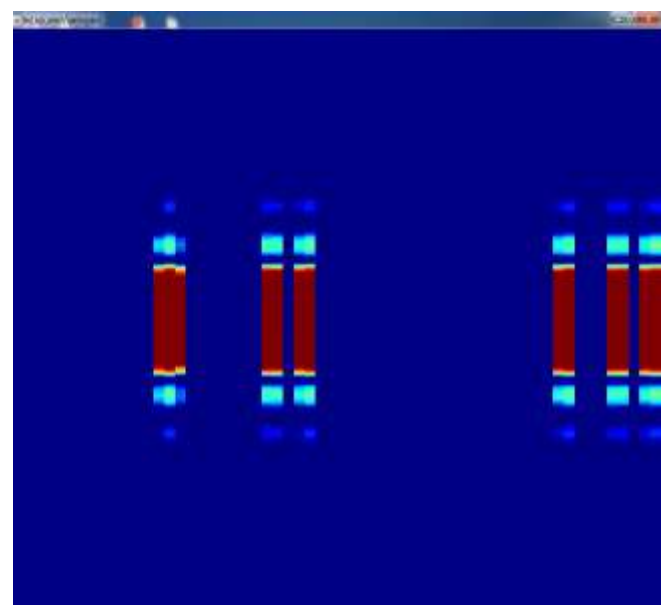

Figure 9 Spectrogram 2

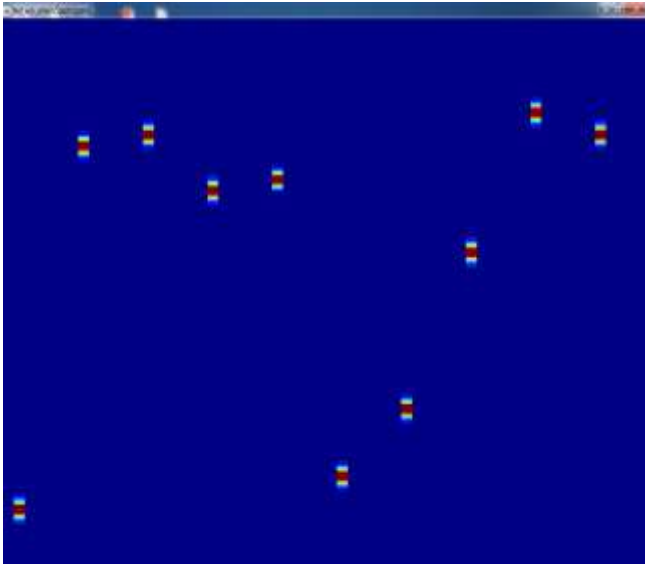

Figure 10 Spectrogram 3

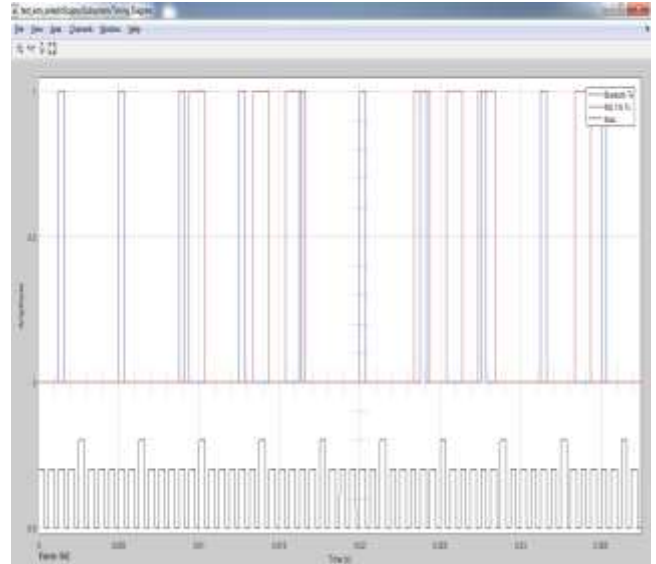

Figure 13 Timing Diagram

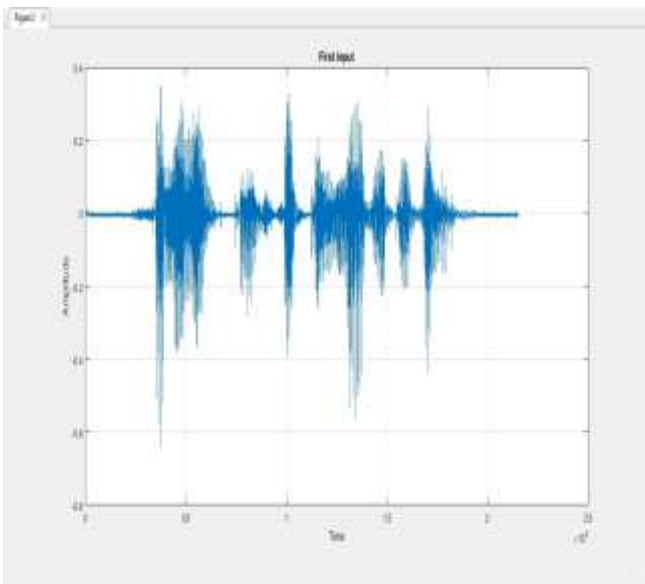

Figure 11 Input Data 1

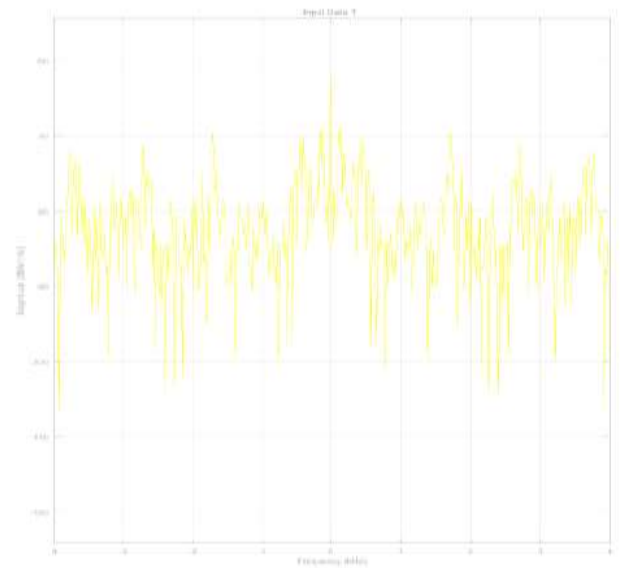

Figure 14 First Transmitter Data

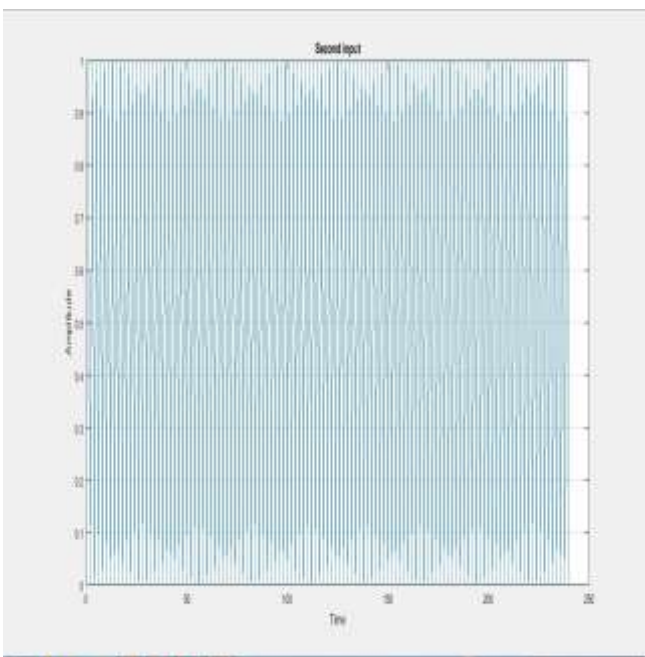

Figure 12 Input Data 2

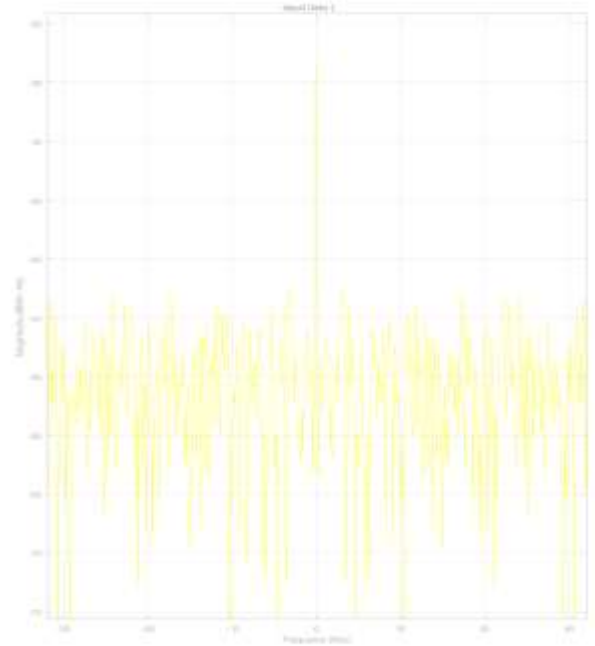

Figure 15 Second Transmitter Data

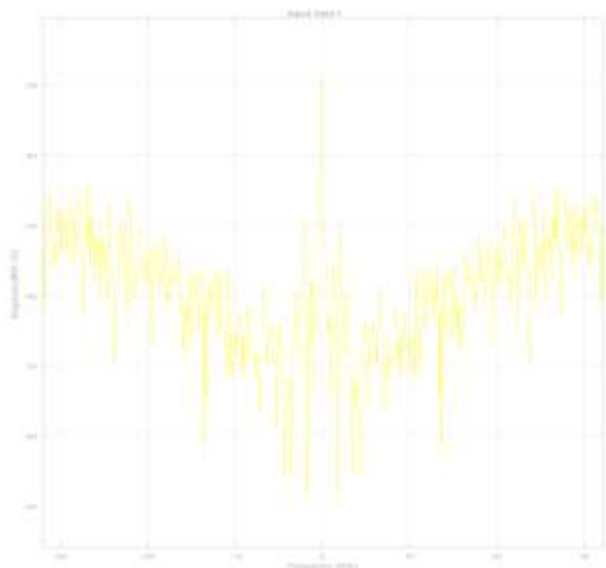

Figure 16 Third Transmitter Data

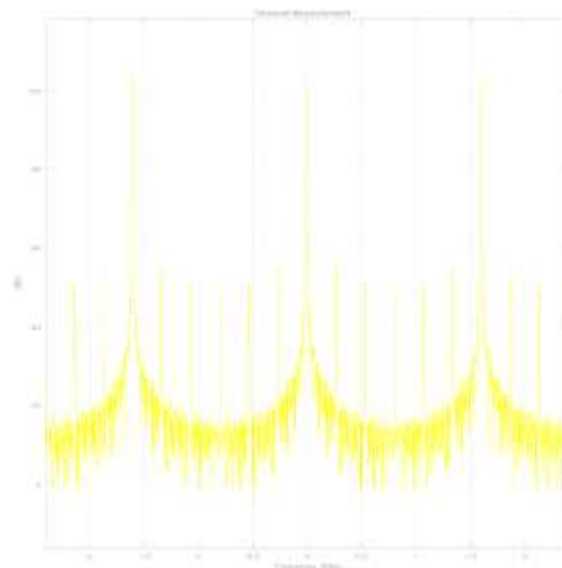

Figure 19 Channel Measurement

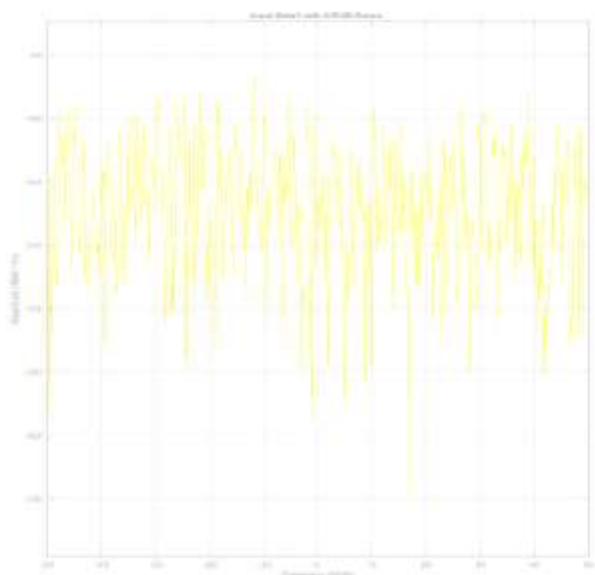

Figure 17 First Transmitter data with AWG Noise

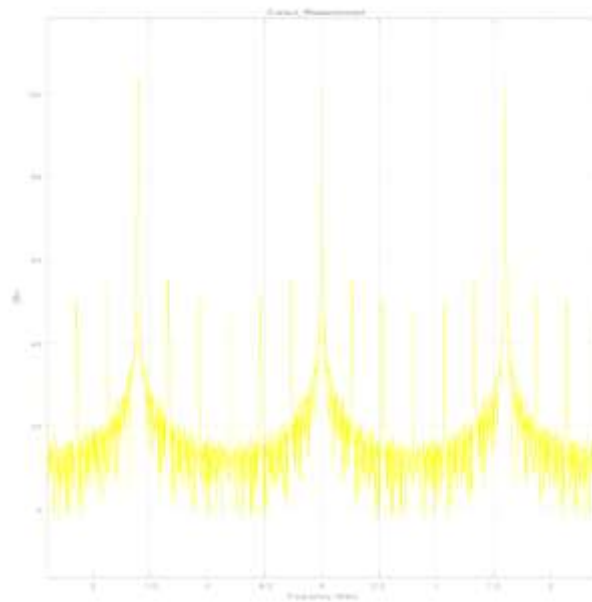

Figure 20 Cursor Measurement

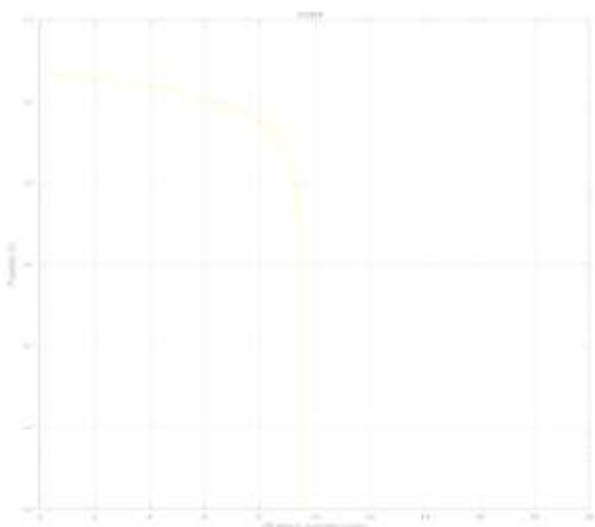

Figure 18 complementary cumulative distribution functions

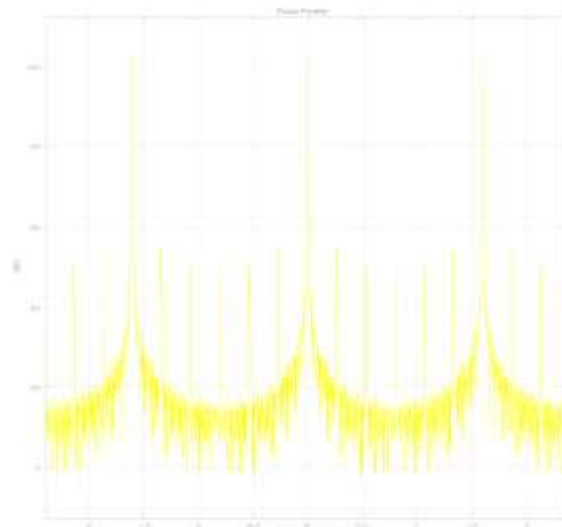

Figure 21 Peak Finder

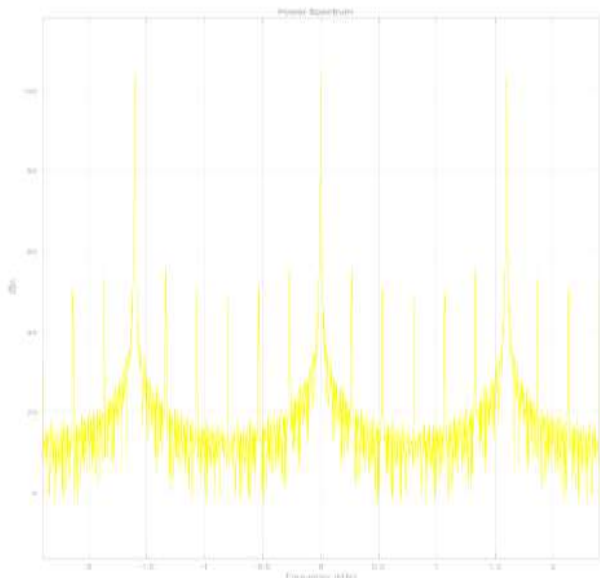

Figure 22 Power Spectrum

VII. CONCLUSION

These systems are imagined to have many cheap sensors with detecting, information handling and communication segments. They normally work in unattended mode, convey over short separations and utilize multi bounce communication.

The analysis of the performance of new simulation methodology of wireless sensor networks (WSN) was presented. MATLAB/ Simulink was used as the tool to build the simulation environment. The strength of this simulation method falls in the ability to study the effect of different physical layer parameters (channel noise and interference, Signal to noise ratio...etc.) on the system behavior.

REFERENCES

- [1] A. S. Tanenbaum and D. J. Wetherall. "Computer Networks". Prentice Hall, 2010.
- [2] B. Titzer, D. Lee, D. J. Palsberg, "Aurora: Scalable sensor network simulation with precise timing," in Proceedings of the 4th international symposium on Information processing in sensor networks. IEEE Press Piscataway, NJ, USA, 2005.
- [3] D. Swain, G. Bishop-Hurley, and J. Griffiths. Automatic cattle control systems –grazing without boundaries. Farming Ahead, June 2009.
- [4] G. Gupta, S. C. Mukhopadhyay, M. Sutherland, M., S. Demidenko, "Wireless Sensor Network for Selective Activity Monitoring in a home for the Elderly", Proceedings of 2007 IEEE IMTC conference. Poland, Warsaw 2007.
- [5] H. A. Nguyen, A. Forster, D. Puccinelli, and S. Giordano. An Experimental Study of Sensor Node Lifetime. In Proceedings of the 7th IEEE International Workshop on Sensor Networks and Systems for Pervasive Computing (PerSens), Seattle, WA, USA, 2011.
- [6] J. A. Lopez Riquelmea, F. Sotoa, J. Suardiaza, P. Sancheza, A. Iborraa, and J. A. Verab. Wireless Sensor Networks for precision horticulture in Southern Spain. Computers And Electronics in Agriculture, 68(1), 2009.
- [7] J. Kulik, W. Heinzelman, and H. Balakrishnan, "Negotiation-based protocols for disseminating information in wireless sensor networks," Wireless Networks, March 2002.
- [8] J. Polley, D. Blazakis, "Atemu: A fine-grained sensor network simulator," in Sensor and Ad Hoc Communications and Networks, 2004. IEEE SECON 2004. 2004 First Annual IEEE Communications Society Conference on, 2004
- [9] L. Girod, N. Ramanathan, "A Software Environment for Developing and Deploying Heterogeneous Sensor Actuator Networks," Center for Embedded Network Sensing, p. 101, 2007.

- [10] Qutaiba Ali, "Simulation & Performance Study Of Wireless Sensor Network Using MATLAB" January 2011.
- [11] S. Bhatti, J. Carlson, H. Dai, J. Deng, J. Rose, A. Sheth, B. Shucker, C. Gruenwald, A. Torgerson, and R. Han. Mantis os: An embedded multithreaded operating system for wireless micro sensor platforms. CM/Kluwer Mobile Networks & Applications (MONET), Special Issue on Wireless Sensor Networks, 10(4), August 2005.
- [12] V. Raghunathan, C. Schurgers, Park, S., and M.B. Srivastava, "Energy-aware wireless microsensor networks," IEEE Signal Processing Magazine, Volume: 19 Issue: 2, March 2002.

Umesh Kumar, Department of Computer Science and Engineering, Feroze Gandhi Institute of Engineering and Technology, Raebareli, India.

Dr Neelendra Badal, Associate Professor, Department of Computer Science and Engineering, Kamla Nehru Institute of Technology, Sultanpur, India.