

# Performance Analysis of Wavelength Division Multiplexed Passive Optical Network (WDM-PON) with implementation of DCF

Abhishek Gupta

**Abstract**— In conventional C-band implementation with DCF WDM-PON prototype are using bit rate of 20Gb/s for upstream and 20Gb/s for downstream hence power budget chart hold good for both upstream and downstream. This prototype delivers good Q-Factor and tolerable BER for 40Km that is considerably higher than Conventional architecture.

Caused by the broadband services, bandwidth demand is growing increasingly and resulting in successive increase in the size of produced traffic in our communication networks. It forces us to implement future admittance network in our zones.

This thesis mainly focused and explained the design and formation of a passive optical network (PON). The basic approach of this proposal is to build a invented impression based on simulation approach that will allow us to analyze in deep on fiber to the home systems and optimize the designed system. To design above said system, different elements of the system will be studied after that optical fiber will be studied in detail.

FTTx networks along with point-to-point and point-to-multipoint architectures will be followed by theoretical part of the network, moving to escalating at length on PON and accomplish which of its technologies will be the best suitable for future. Finally, simulation tool will meet the project necessities will be selected, the design of PON system will be accomplished and in the simulation results which explain that the network is possible.

**Index Terms**— Passive optical network, Wavelength division multiplexing, Fiber to the home, Photonic crystal fiber, dispersion compensation fiber, single mode optical fiber

## I. INTRODUCTION

Wavelength division multiplexing-PON (WDM-PON) has been considered as a powerful means to meet the ever-increasing bandwidth demand by introducing multiple wavelengths and using wavelength division multiplexed multiplexer (WDM Mux)/ demultiplexer (WDM DeMux) at server end, user end and remote node (RN) to distribute wavelengths. Research in WDM-PON using multiple access techniques has been proposed. To obtain a low-cost WDM-PON requires colorless optical network units (ONU), and different types of colorless light sources are applied. The key feature of a PON NETWORK is the presence of only passive components in the field, i.e. elements that operate without any electrical power. Fiber connectivity is established from the optical line terminal (OLT) at central office (CO) to the optical network units (ONU) at customer premises. The passive elements are placed at the remote node (RN), which sits close to ONU. [1] A novel design of the OLT and DWDM-PON ONUs lessens the system cost significantly: 1) the need of variable lasers and receivers at the optical line

terminal are shared by all ONUs on the network to lessen the transceiver count and 2) the fast tunable lasers not only produce downstream data traffic but also offer DWDM-PON ONUs with optical CW bursts for their upstream data broadcast. Results from an investigational system test bed support the viability of the proposed SUCCESS design. SUCCESS DWDM-PON simulation results gives that it bidirectional broadcast between the OLT and ONUs over multiple wavelengths can be offered effectively with reduced tunable transmitters and receivers. [2] By combining of WDM in a PON NETWORK enables the network to support much higher bandwidth then conventional PON. FTTH networks belong to the family of FTTx broadcast systems within the world of telecommunications. These networks, which are considered broadband, capable to transmit huge quantities of data, audio and video with large bit rates. [3] TDM-PON and WDM-PON; these are only the practical choice for future optical networks. A TDM-PON shares a single-broadcast channel with multiple operators in time domain. Then, there exists tight coupling between operators. A WDM-PON offers point-to point optical connectivity using a dedicated pair of wavelengths per user. [4] It first gives why passive optical network is a very general and famous design today. And then they proposed some technologies in depth to implement the proposed design. They also include EPON NETWORK and GPON NETWORK systems other advanced PON NETWORK systems that offer higher bandwidths. [5] It gives Power saving ad-hoc Report to make energy efficient passive optical network to give efficient access. [6]

## II. SYSTEM ARCHITECTURE

A PON is a fiber network that only uses fiber and passive components like splitters and combiners rather than active components like amplifiers, repeaters, or shaping circuits. The low cost of passive components means simpler systems with fewer components that fail or require maintenance. This Design with simulation of C-band WDM-PON as shown in Fig. 1

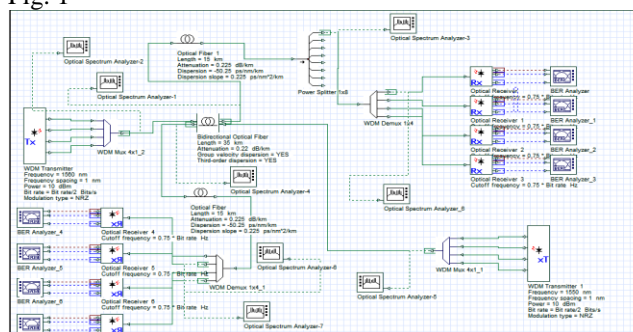

Figure 1: System design with simulation of C-band WDM-PON layout

## Performance Analysis of Wavelength Division Multiplexed Passive Optical Network (WDM-PON) with implementation of DCF

OLT is to control the information flow across the ODN, going both directions, while being located in a central office. OLT has two flow directions: upstream (getting and distributing different type of data and voice traffic from users) and downstream (getting data, voice and video traffic from metro network or from a long-haul network and send it to all ONT modules on the ODN. Proposed design is used the four wavelength which has transmitting of 5Gbps each wavelength, it has totally 20Gbps capability. We have required the central office for making these wavelengths; we use the dispersion compensation fiber (DCF) for handle the dispersion at 20 GB/s.

As a first step in our work, dispersion compensation will be achieved if the total dispersion of the SMF and that of the DCF are matched. Because the dispersion of the DCF can be quite large near cutoff, relatively small lengths of DCF are needed to compensate a given amount of positive dispersion. The second step to get a better control is to match the dispersion slopes of the SMF and the DCF as well. This can be achieved if the ratio of slope to dispersion for the SMF equals that of the DCF.

These wavelength signals are de-multiplexed at receiver end and set to each ONUs. We analyzed through BER and differentiate with input signals

### III. SIMULATED PROTOTYPE DESIGN

Optical communication systems are increasing in complexity on an almost daily basis. The design and analysis of these systems, which normally include nonlinear devices and non-Gaussian noise sources, are highly complex and extremely time-intensive. As a result, these tasks can now only be performed efficiently and effectively with the help of Optiwave 12.0 to simulate the conventional C-band Wavelength Division Multiplexed Passive Optical Network (WDM-PON) architecture which comprises of WDM Mux/DeMux, tunable receivers, tunable transmitter. C-band WDM-PON prototype is demonstrated/simulated to provide 20Gb/s downstream and 20Gb/s upstream bandwidth. This prototype system offers minimum loss budget.

We used the conventional C band wavelengths from 1560nm to 1563nm for downstream and 1550nm to 1553 nm for upstream with 1 nm spacing. We used the four wavelengths each of 5 GB/s data. 20 GB/s is downstream and 20 GB/s is upstream data rate.

OptiSystem was combined to set a model by comparing the dispersion tolerance of different code modulation formats. A simulation analysis is also made between the different duty ratios of the DQPSK and IRZ. Compared with the NRZ type, the IRZ has a better anti-dispersion property, channel crosstalk suppression ability and higher spectrum efficiency. The optical line terminal (OLT) consists of N channels, and there is a Mach-Zehnder modulator (MZM) in each channel to generate optical signals for downstream transmission. The data sequence with bit rate is generated by a pseudo-random bit sequence (PRBS) generator.

### IV. SIMULATED RESULT

Spectrum analyzer is used to observe the WDM multiplex signal when WDM multiplexed when multiplexed signal with a spacing of minimum 1nm can be designed caring the wavelength observed in between 1560 to 1563nm as shown in Fig. 3.

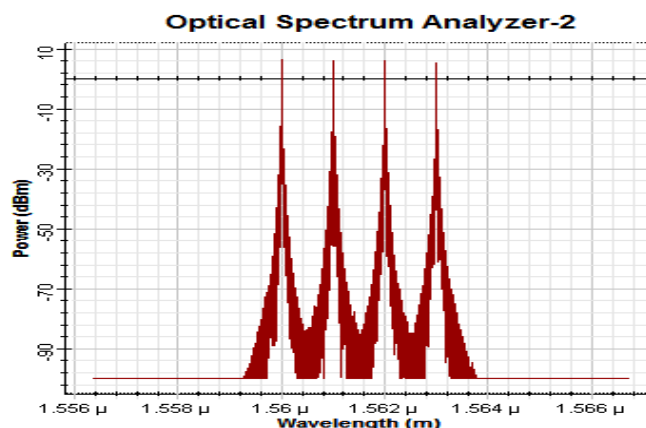

Figure 2: Multiplexed signal at OLT

It was observed there extra a reduction in 10dbm when these multiplied signals travel around 40 km to 50 km of about 0.22db/km along with 16.75ps/nm/km respective.

Above 5Gbps the phenomena of dispersion impacted more on optical fiber performance which can be compensated through dispersion compensation fiber (DCF).

ONU is placed at the terminal of fiber multiplexed signal enter into ONU which demux any selectable waveform to get desired wavelength as shown in Fig. 3 with its define power.

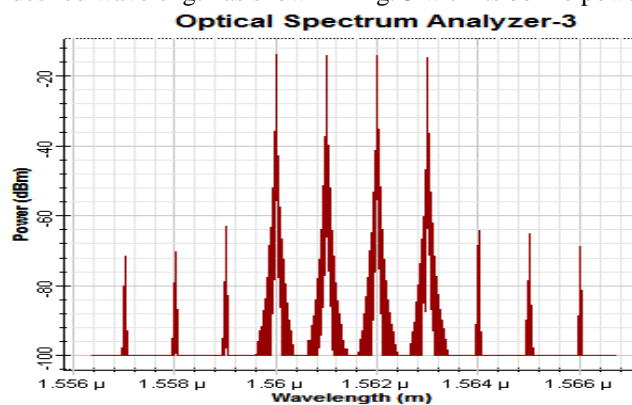

Figure 3: Downstream optical spectrum at ONU DeMux

Eye diagram is used for analysis BER at ONU as shown in Fig. 2.

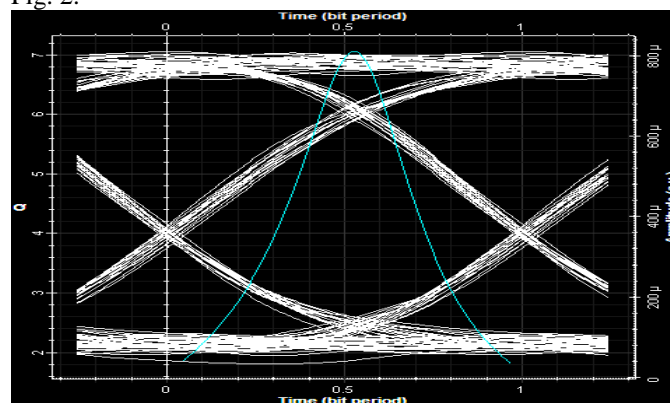

Figure 4: Eye diagram at ONU

WDM PON with 4 wavelengths is depicted in this design due to the dispersion occurring in the system bit error at receiver is high and thus degrading the quality factor (Q). This poor Q factor restrains the communicated data rates. To enhance the BER and Q factor of this design dispersion of the system can minimize by dispersion compensation techniques (DCF).

There are two ways to perform the simulation. in first we kept power constant while is length is varying, for example if power is kept 10dbm with a length changing of 4 0to 50 km. it is observed that max Q-factor start degrading after 40km in other case if length is kept constant say about 40km.anf power is configure from 0dbm to 10dbmmax Q-factor obtain is higher is original one.

## V. POWER BUDGET CALCULATION

For designing and installation of any optical network system design engineer so as to maintain Q-factor and bit error rate.

For designing and installing any passive optical network system, power budget analysis is highly recommended to make the system limits as per our desired one. Calculation helps us to know the input power range along with power margin of any architecture.

There are two type network losses occurred: Passive & Active due to the respective parts used in simulation. Active parts are installed at OLT and ONU while passive parts are lies between OLT. and ONU.

Passive losses comprises of fiber loss, connector loss, splice loss and couplers or splitters in the link; while active loss are because of wavelength multiplexer, transmitter power and receiver sensitivity.

In simulation, we have considered, C-band WDMPON with bit rate of 20 GB/s (both in upward and downward).

$$P_{tx} = P_{rx} + C_L + M_s$$

Where  $C_L$  is expressed as

$$C_L = \alpha L + \alpha_{con} + \alpha_{splice} + \alpha_{splitter}$$

$\alpha$  - Fiber attenuation (dB/Km)

L - Length of fiber (Km)

$C_L$  - Channel loss (dB)

$M_s$  – Safety Margin (dB)

A loss in system comprises some fixed losses of:

- Fiber attenuation
- Length of fiber
- Splice & splitter losses

Minimization of numbers of connectors & splitter helps to reduce few losses in the system.

In this simulation test, we have consider fiber losses of about 0.22db/km for 50km of length with splitter loss of  $3.5 \log_2(n)$ . Where n is the output port of splitter. Thus build up total fiber losses become 11 dB. Thus, For 8 ports, the splitter losses is 10.5dB while for 4 ports, it is 7 dB.

Refer acceptable range off Receiver sensitivity for PIN diode receiver of -31 dBm. In simulation, Input power feds in the range of 0 dBm to 10 dBm.

From the above equation

$$0 = -31 \text{ dBm} + 11 \text{ dB} + 1.2 \text{ dB} + \alpha_{splitter} + M_s$$

$$\alpha_{splitter} + M_s = 18.8 \text{ or}$$

$$\alpha_{splitter} = 18.8 - M_s$$

by considering  $M_s = 6 \text{ dB}$

$$\alpha_{splitter} = 18.8 - 6 = 12.8 \text{ dB}$$

Similarly for 10 dBm input power

$$10 = -31 \text{ dBm} + 11 \text{ dB} + 1.2 \text{ dB} + \alpha_{splitter} + M_s$$

$$\alpha_{splitter} = 22.8 \text{ dB}$$

Thus, from calculation it is observed that Splitter loss of system without performance degration us around 12.8 to 22.8dB.

For 'n' = 16 to 64; we can provide up to 64 end users.

Here additional 8.8dB is utilize for increasing the length of fiber upto 40km (for future requirement).

## 1 CONCLUSION

Method of DCF (dispersion compensation fiber) surely decrease the dispersion effect which is provide by given simulation that leads to better Q factor and BER when measured at 50km or higher.

Because of this, B/W is increase upto 20GB/s in both upward and downward stream with the use of only 4 wavelengths.

**Table 1: Length vs Q-Factor**

Length (Km)	Existing C-band WDM-PON(Q-factor)	Proposed WDM-PON With DCF (Q-Factor)
30	4.87	6.75
40	4.03	6.19
50	2.86	5.94

**Table 2: Length vs BER**

Length (Km)	Existing C-band WDM-PON(BER)	Proposed WDM-PON With DCF (BER)
30	0.8036108	0.4036108
40	1.2132396	0.6432396
50	3.0246738	1.8316738

Thus with 4 wavelength, the use of lesser line cards are used in system at TX and RX side. As a result lesser power consumed & system is more efficient both in terms of cost and operational as compared with legacy design.

## REFERENCES

- [1]-Maier, G., Martinelli, M., Pattavina, A. and Salvadori, E. (2000). Design and cost performance of the multistage WDM-PON access networks. *J. Light. Technol.* 18 (2): 125–143.
- [2]-An, F., Kim, K. S., Gutierrez, D., Yam, S., Hu, E. S., Shrikhande, K. and Kazovsky, L. G. (2004). SUCCESS: A Next-Generation Hybrid WDM / TDM Optical Access Network Architecture. *J. Light. Technol.* 22 (11): 2557–2569.
- [3]-Banerjee, A., Park, Y., Clarke, F., Song, H., Yang, S., Kramer, G., Kim, K. and Mukherjee, B. (2005). Wavelength-division-multiplexed passive optical network (WDM-PON) technologies for broadband access: a review. *Journal of Optical Networking*. 4 (11): 737–758.
- [4]-Lee, C., Sorin, W. V. and Kim, B. Y. (2006). Fiber to the Home Using a PON Infrastructure. *J. Light. Technol.* 24 (12):4568–4583.
- [5]-Effenberger, F., Cleary, D., Haran, O., Kramer, G., Li, R. D., Oron, M. and Pfeiffer, T. 2007. An introduction to PON technologies. *IEEE Commun. Mag.* 45 (3) :17–25.
- [6]-Otaka, A. 2008. Power saving ad-hoc Report. IEEE. 1–7.
- [7]-Ruffin, A. B., Downie, J. D. and Hurley, J. 2008. Purely passive long reach 10 GE-PON architecture based on duobinary signals and ultra-low loss optical fiber. Conference on Optical Fiber Communication/National Fiber Optic Engineers Conference. 17–19.
- [8]-Effenberger, F. and El-Bawab, T. S. (2009). Passive Optical Networks (PONs): Past, present, and future. *Opt. Switch. Netw.* 6 (3) :143–150.
- [9]-Koutitas, G. and Demestichas, P. 2010. A Review of Energy Efficiency in Telecommunication Networks. *Telfor J.* 2 (1) :2–7.
- [10]-Dixit, A., Lannoo, B., Das, G., Colle, D., Pickavet, M. and Demeester, P. (2011). Flexibility Evaluation of Hybrid WDM / TDM PONs. *IEEE. International Conference on Advanced Networks and Telecommunication Systems (ANTS)*.1–6.