

Bluetooth Based Patient Monitoring System

Tabish azad, Saima Beg, Naushin Kulsum, Shaquib Khan, Atif Pasha

Abstract— This paper, presents a Wireless Sensor Network (WSN) for monitoring patient's physiological conditions continuously using Bluetooth. Here the physiological conditions of the patient's are acquired by sensors and the output of these sensors is transmitted via Bluetooth and the same has to be sent to the remote wireless monitor for monitoring the observed patient's physiological signal. The remote wireless monitor is constructed of Bluetooth and Personal Computer (PC). The measured signal has to be sent to the PC, which can be able to monitor. Bluetooth is having a better data transmission rate with less power consumption. The first procedure of the system is that the wireless sensors are used to measure heart rate, temperature and blood pressure from human body using bio-sensors. Next procedure of the system is to process the signals using a microcontroller. The final procedure is to transmit the processed signals using Bluetooth and monitoring the signal in a PC & smartphones.

Index Terms— Wireless Sensor Network, Physiological Signals, Microcontroller, Bluetooth, Personal Computer, Smart phone.

I. INTRODUCTION

The present patient monitor systems [1] in hospitals allow continuous monitoring of patient vital signs, which require the sensors to be hardwired to nearby, bedside monitors or PCs, and essentially confine the patient to his hospital bed. Even after connecting these systems to a particular patient, a paramedical assistant need to continuously monitor and note down all the vital parameters [2] of a given patient by keeping track of all of his/her records manually. Adopting such a method is error prone and may lead to disaster in the case of a human error. In the current proposed system the patient health is continuously monitored by the Mobile multi patient monitoring system and the acquired data is transmitted to a centralized microcontroller using Wireless Sensor Networks. A Bluetooth transceiver is connected to every patient monitor system that consumes very low power and is extremely small in size[2].

These are specifically designed for low power consumption, with minimal circuit components intended for small packet, long distance range applications and typically consist of a low power controller with minimal resources and interface capabilities. These Bluetooth is having a data transfer rate of about 10 m. So the Wireless Sensor Networks seem to be a

Manuscript received March 18, 2015.

Tabish azad, Under Graduate Students (B.Tech. Electronics and communication Engineering, Integral University,Lucknow)

Saima Beg, Asst. Professor,Dept. of ECE, Integral University,(Lucknow, U.P., India)

Naushin Kulsum, Under Graduate Students (B.Tech. Electronics and communication Engineering, Integral University,Lucknow)

Shaquib Khan, Under Graduate Students (B.Tech. Electronics and communication Engineering, Integral University,Lucknow)

Atif Pasha, Under Graduate Students (B.Tech. Electronics and communication Engineering, Integral University,Lucknow)

perfect fit for remote patient monitoring[3].

To improve the accuracy and to increase the efficiency of the above processes a real time patient monitoring system based on Wireless Sensor Networks[3] and a centralized microcontroller is integrated with a Bluetooth module is designed. This paper describes an independent system that automatically logs vital parameters of patients for easy access. The data is accessible to doctors through mobile device for convenience if needed.

II. OBJECTIVE

This proposed system has several nodes for signal acquisition and transmission. They are,

- (i) Signal acquisition node
- (ii) Microcontroller processing node
- (iii) Bluetooth transfer node
- (iv) PC monitoring node

The designing of the above nodes are necessary to implement the system in practical. The signal acquisition node is used to collect the physiological data from the patients. The collected signals are processed by the microcontrollers in this microcontroller processing node. These TTL logic signals are transmitted by a Bluetooth transmitter from the patient. Similarly a Bluetooth receiver is used to receive the signals by the caretaker's end. This process is controlled by the Bluetooth transfer node. Finally, the PC monitoring node monitors the received signals. The entire process is a real time process, which is controlled by a specific special purpose computer.

III. METHODOLOGY

A. Block Diagram

The following figure shows the functional block diagram of the system hardware.

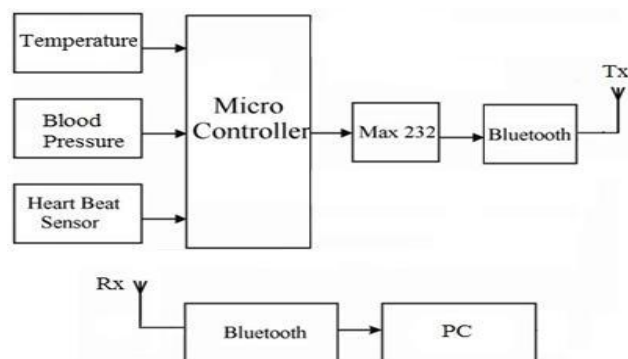

Figure 1: Functional block diagram of the system hardware[4]

B. Block Description

The system has been designed to take several inputs to

measure physiological parameters of human such as temperature, heart rate and blood pressure. The inputs from the sensors are integrated and processed. The results are sent through the Bluetooth Module to a host computer, which stores the data into an Access Database. The values can then be displayed on the Graphical User Interface (GUI) running on a computer. If it is inferred that the person is medically distressed, an alarm may be generated. Once the user has connected to the receiver unit, data is automatically updated on the screen. Beats per minute (BPM), body temperature and Blood Pressure (BP) is given on the display. The proposed system consists of three sensors: a temperature sensor, heart beat sensor and a blood pressure sensor. The description of individual sensors follows.

C. Temperature Sensor

The LM35 series are precision integrated -circuit temperature sensors, with an output voltage linearly proportional to the Centigrade temperature. Thus the LM35 has an advantage over linear temperature sensors calibrated in ° Kelvin, as the user is not required to subtract a large constant voltage from the output to obtain convenient Centigrade scaling[6].

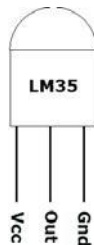

Figure 2: Temperature sensor

The LM35 is rated to operate over a -55°C to $+150^{\circ}\text{C}$ temperature range. The above figure shows the temperature sensor LM35.

D. Heart Beat Sensor

The system consists of an infrared (IR) LED as transmitter and an IR photo -transistor as a receiver that acts as a fingertip sensor. The following figure shows the measurement of heart beat measurement using IR sensors[4].

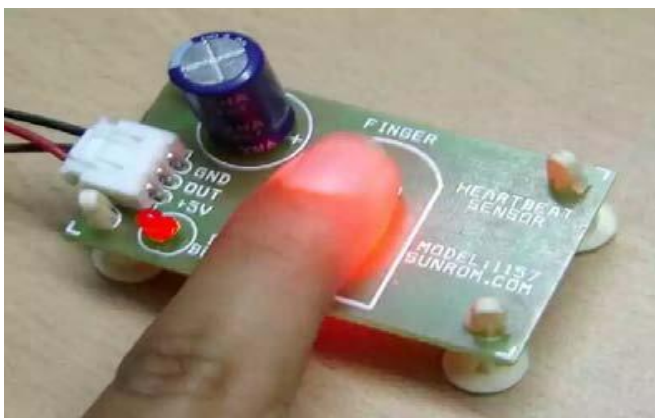

Figure 3: Heart Beat measurement

The sensor consists of a super bright red LED and light detector. The LED needs to be super bright as the maximum light must pass spread in finger and detected by detector. Now, when the heart pumps a pulse of blood through the

blood vessels, the finger becomes slightly more opaque and so less light reached the detector. With each heart pulse the detector signal varies. This variation is converted to electrical pulse. This signal is amplified through an amplifier which outputs analog voltage between 0 to 5V logic level signal[4].

IV. BLOOD PRESSURE SENSOR

The blood pressure sensor is used to measure the human blood pressure by non-invasive method. It measures the systolic, diastolic and mean arterial pressure using the oscillometric technique[5]. In this sensor, the pressure ranges from 0 mm Hg to 250 mm Hg. It works with the response time of 100 microseconds. These sensor data are given to the microcontroller for processing them. So, the data is converted into the Bluetooth signal which can be transmitted through a Bluetooth transmitter[5]. Generally the PIC16F877A controllers are used for processing because of their better efficiency. The Bluetooth of the PC is used as the receiver end. It receives the transmitted signals and stores on a memory location. Similarly, the PC monitors the received signals continuously. So, the entire process is called as a real time monitoring process.

V. FEATURES

The important features of this proposed system are,

- The Bluetooth technology is mostly used in most electronic equipments like mobile phones, tablets, laptops, etc., So we can configure our personal mobile phones as the receiver end.
- This system also can be implemented even in remote (mobile) patients too.
- This system can be easily implemented in society.

These are some features of the proposed model.

VI. RESULTS

The entire system output can be simulated before it is going to implement in hardware. This system monitors the heart rate, temperature and the blood pressure in the PC screen by using the Bluetooth technology. This entire system requires less power which can even implemented in remote (mobile) patients too. We can add some another parameters as per our necessary.



Figure 4: Hardware Kit

VII. CONCLUSION

This paper shows the novel approach of the wireless data transmission using Bluetooth technology for patient's physiological signal monitoring. The important specification of this paper is based on the real time monitoring of biosignals. This above process can be also done by using LAN technology and by another wired data transmission technologies.

REFERENCES

- [1] Neha Mahajan, K.T.V. Reddy, "Patient Monitoring using ZigBee technology," National conference on Nascent trends in Information and Communication technologies, Equinox 2010.
- [2] Neha Mahajan, K.T.V. Reddy, "Wireless Monitoring of Physiological parameters using ZigBee technology," in CIT journal of Research, Volume 1, Issue 3, Nov. 2010, Pages: 154-162.
- [3] Y. Hao and J. Foster, "Wireless sensor networks for health monitoring applications," *Physiological Meas.*, vol. 29, no. 11, pp. R27-R56, 2008.
- [4] S. Ohta, H. Nakamoto, Y. Shinagawa, and T. Tanikawa, "A Health monitoring system for elderly people living alone," *J. Telemedicine and Telecare*, vol. 8, no. 3, pp. 151-156, Jun. 2002.
- [5] N. Hamza, F. Touati, and L. Khriji, "Wireless biomedical system design based on ZigBee technology for autonomous healthcare," in *Proc. Int. Conf. Commun., Comput., Power (ICCCP'09)*, Muscat, Feb. 15-18, 2009, pp. 183-188.
- [6] Sahandi, R., Noroozi, S., Roushanbakhti, G., Heaslip, V. & Liu, Y. "Wireless technology in the evolution of patient monitoring on general hospital wards". *Journal of Medical Engineering and Technology*, vol.34, no.1, pp.51-63,2010