

Integration of Digital Modulator and RF up converters for DVBC/T applications

Mr.Nanda Kishora Holla , Dr. Siva S. Yellampalli.

Abstract— Digital Modulators along with RF up converters are used in Trans-modulation applications to convert one form of signal in to another form. The output from the Modulator needs to be processed further to use in DVBC or DVBT applications. Modulators used for commercial applications in TV band need to be designed carefully since the effect of 3rd harmonic generally affect the quality of the signal. This technical paper addresses the issues in handling the modulated signal for the commercial use.

Index Terms—High Definition (HD), Intermediate Frequency (IF), Network Interface Module (NIM),

I. INTRODUCTION

Trans-modulation is a process of converting one form signal in to another form where in digital modulators are used. The Digital modulator may be stand alone silicon or a programmable type modulator. Any commercially available silicon can be used for this purpose. However in many cases the output from the Modulator will be either ZIF or LIF. Hence to upscale the modulator output, it is essential to use RF up converters. Typically to handle I & Q signal, it is essential to use IQ modulators. However during the modulation, the distortions due to 3rd harmonics can not be ignored. An exclusive circuit component needs to used suppress these harmonics. Once the harmonics are suppressed, the signal can be amplified to use in DVBC or DVBT applications.

There are different types of signal sources like DVBC, DVBT or DVBS, which need to be accessed by the receivers. When it comes to TV program broadcasting, there are three different types of distribution mechanisms which are in place as on today, namely, over the air (OTA) terrestrial method, direct to home (DTH) satellite method, Operator-specific Cable Television (CATV) method.[1] Types of signal reception can be listed as follows:

- Receiving the digitized signal from Satellite using DVBS Set top box
- Receiving the digital Cable signal through DVBC Set top box
- Terrestrial signal reception using DVBT Set top box
- Digital signal reception in Hand held devises such as mobile phones

Manuscript received November 09, 2014.

Nanda kishora Holla, B.E., in Electronics and communication Engineering from University of Mysore and M.Tech in VLSI design and Embedded system from VTU ,Belgaum.

Dr. Siva S. Yellapalli, Phd in Micro electronics and working as Professor at VTU Extension Center, UTL technologies, Bangalore .

- Digital signal reception in PC / Computers

By using Trans-modulators, the required form of signal can be obtained. For example DVBC 64 QAM signal can be tran-modulated in to QPSK signal or to any other required form. It is process of re constructing signal, which can be used to for redistribution as per the user need or requirement.

Generally the transport stream from the demodulator section of the receivers will be taken as input to the modulator. The modulated signal is transmitted over cable or it can be retransmitted over air using small antenna. Power amplifier can be switched on to get the required amplified signal, which need to be decided based on the range of signal transmission required. Since the sources of contents are available in different forms like DVBC/T/S/ or in the form of IP data, the receivers need to have capabilities to work with different signal sources. It will be very useful for the users if a single receiver can do multiple functions. This is only possible by designing front-end Network Interface Module (NIM) with enhanced capabilities to access different signal sources. Trans-modulation is an one of the additional requirement which can be incorporated at NIM architecture. Network Interface Module (NIM) is a front-end channel receiver block in the HD receivers and Set Top Boxes (STB). NIM selects the required channel from the available input frequency spectrum and down coverts it to an Intermediate frequency.[3,4]

II. THE DESIGN CONCEPT

Commercially available modulators used in digital environment today will take Transport streams (TS) as input. Programmable Modulators work on SDR (Software defined Radio) based technology, where in the required output can be changed by changing the software. The output from the modulator will be ZIF or LIF, which need to be processed further using RF up converters. The below block diagram in Figure 1 shows the interfacing of Modulators with IQ RF up converter.

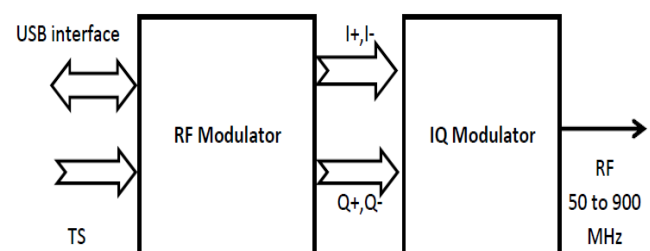

Figure1: RF modulator and IQ modulator interface
RF Modulator:

Programmable RF modulator can be connected to USB port through USB controller silicon. Transport stream is taken as input and operation is controlled through IIC. Universal modulator silicon can be programmable for different types like QAM, ATSC, QPSK etc. The output of the modulator is ZIF or LIF which need to be scaled up in further sections of the module. The programmable architecture of Software Radio promotes a flexible implementation of modulation methods. This flexibility also translates into adaptively, which is used here to optimize the throughput of a wireless network, operating under varying channel conditions.[2,5-7]

RF up converter:

Suppose if the out put from modulator is I and Q differential signals, then we need to use IQ modulator to handle these signals. To get DVBC or DVBT signals for a TV band usage, we need to use IQ modulators silicon like RF2080 or TRF372017. These IQ modulators are also called as RF up converters since the base band frequency is transformed in to TV channel frequency range. The output from IQ modulator will be in the range of 50 MHz to 4 GHz depending on the specification of the modulator.

However for DVBC/T TV channel applications, the range from 50 MHz to 900 MHz is desirable with suppressed 3rd harmonic components.[8] Device programming is done through simple 3 wire serial interface. RFMD2080 has integrated VCO inside the silicon along with fractional N-Synthesizer, which can give RF output of 45 MHz to 2700 MHz.

The modulator output is differential and requires a balun along with simple matching circuit. The modulator output is high impedance, consisting of approximately 2K Ohm resistance in parallel with some capacitance, approximately 1pF. The modulator output does not require a conjugate matching network. It is a constant current output which will drive a real differential load of typically 200 Ohms. Since the mixer output is a constant current source, a higher resistance load will give higher output power and gain. A shunt inductor can be used to resonate with the mixer output capacitance at the frequency of interest. This inductor may not be required at lower frequencies where the impedance of the output capacitance is less significant. [9]

III. HARMONICS SUPPRESSION

Suppose the RF up converter works in the range of 50 to 900 MHz, then we need to suppress the 3rd harmonics in this entire range. Theoretically, the odd harmonics generated during the mixing process will have higher amplitude and these signals are the major concerns to affect the quality of the signal,

For example, if the desired channel is tuned to 50 MHz, then the 3rd harmonics will appear at 150 MHz, whose amplitude is good enough to distort the desired signal. Hence the suppression of these harmonics is very much essential. [10-12,14]. But for each input signal, we cannot have Low pass filter to block the harmonics, which is practically not feasible. Commercially available IQ modulators output is not free from 3rd harmonic signals. Hence if we directly amplify the output from IQ modulator, the signal quality will suffer because of harmonics.

Let us take an example of handling signal from 50 MHz to 1GHz., which is generally used for TV channel transmission We can use following filter banks to address the entire desired range as given in Table1.

Table 1: Filter specifications for harmonics suppression

Filter 1	Operating input frequency range:	50 MHz to 90 MHz
	Pass band	0 to 100 MHzs
	Image suppression (Min 40 dB)	For the range 135 to 300 MHz
Filter 2	Operating input frequency range:	91 MHz to 190 MHz
	Pass band	0 to 200 MHzs
	Image suppression (Min 40 dB)	For the range 250 to 600 MHz
Filter 3	Operating input frequency range	191 MHz to 390 MHz
	Pass band	0 to 400 MHzs
	Image suppression (Min 40 dB)	For the range 500 to 1200 MHz

Filter 1 has pass band of 0 to 100 MHz, which will be switched on for the frequency from 50 to 90 MHz.. At this frequency range, the maximum harmonic frequency fall at 300 MHz for 100 MHz input. This filter should be able to cut off image by at least 40 dB.

Filter 2 has pass band of 0 to 200 MHz, which will be switched on for the frequency range from 91 to 190 MHz. When the input is 190 MHz, the 3rd harmonic will be at 570 MHz. Since this filter has capability to attenuate 40 dB for the frequency range from 250 to 600 MHz, the required specifications of image suppression is possible till input frequency of 190 MHz.

Filter 3 has pass band of 0 to 400 MHz, which will be switched on for the range from 191 to 390 MHz. When the input is 390 MHz, the 3rd harmonic will be at 1170 MHz. Since this filter has capability to attenuate 40 dB for the frequency range from 500 to 1200 MHz, the required specifications of image suppression is possible till input frequency of 390 MHz.

Above 390 MHz, the harmonics is falling above 1100 MHz, which is not in the operating range of Cable or Terrestrial TV channel band. Hence no need to use any filter to suppress the harmonics for the input frequency range from 390 to 900 MHz.

However we can have final filter LPF4 at the output to cut off frequencies beyond 1000 MHz. The filter banks to be switched depending on selected frequency range what is discussed. Suitable RF switch with 4 pole can be used for this purpose. [13].

Figure 2 shows the arrangement of filter banks along with the RF switch. RF switch used has 4 selection positions, which can be selected digitally. In the 4th position, no low pass filter is used for the frequency above 390 MHz.

With 7 pole type filters, the better suppression of minimum 40 dB can be achieved. Low insertion loss is the key characteristic of the required filter, typically less than 0.3 dB). Programmable digital filters also can be used for these applications

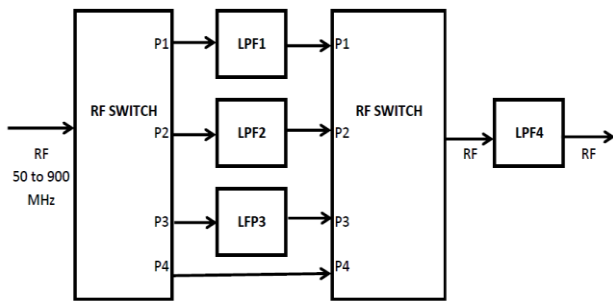

Figure 2: Block diagram filter bank arrangement

RF switch:

CMOS RF switch of 4 pole type is used in this application. Port selection is possible by using 2 select lines. Logic control of 00, 01, 10 and 11 can be used for selection of 4 different positions.

IV. INTEGRATION OF THE BLOCKS

Integration of RF modulator and up converter blocks with Filter bank and RF amplifier is shown in Figure 3

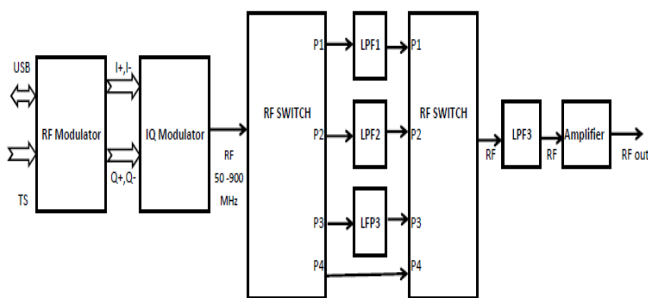

Figure 3: Integration of RF modulator and up converter blocks with Filter bank and RF amplifier

The modulator will take digital transport stream from the demodulator and gives out I and Q signal. or low IF signal. Universal Modulator SOCs are used for this purpose, which adds flexibility to transmodulate the frequency. The IQ signal lines are connected to IQ modulator section to get the RF output. To suppress 3rd harmonic components during mixing at IQ Modulator, a filter bank is attached at the output of modulator. The power amplifier will be used to amplify the RF in case if it needs to be transmitted over air locally. The signal regeneration has many applications. Depending on the requirement, signal can be internally regenerated which can be accessed by other equipments in the home.

Amplifier:

Linear amplifier which can work for the entire frequency range of 50 to 1000 MHz is used. RDA2032Z is used for this application. (Gain max is 38.8 dB at 140MHz) [9]

V. RESULTS

The RF output levels from the IQ modulator / RF up converter is captured here for reference for the different modulated signals. For example, DVBC and DVBT at different frequencies are captured in Figure 4 to Figure 7. Figure 8 and Figure 9 show the RF modulator ZIF out put for DVBC and DVBT signals respectively.

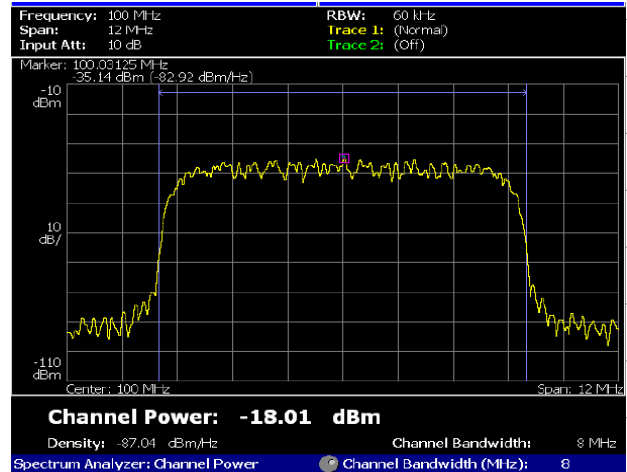

Figure 4: RF up converter out put (DVBC, 256 QAM, symbol rate:6952 Msps @ 100MHz)

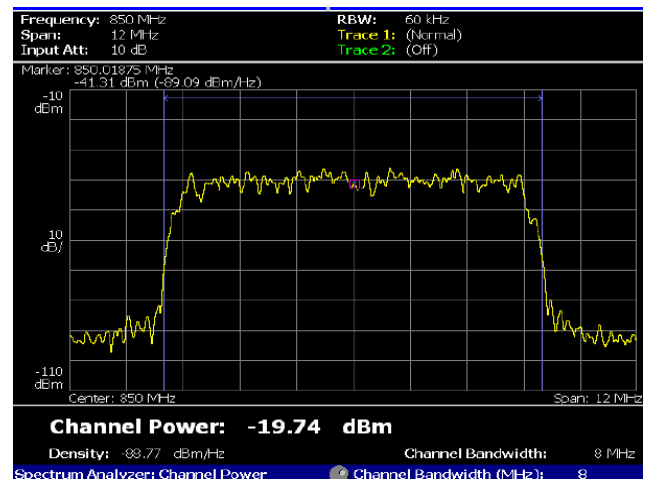

Figure 5: RF up converter out put (DVBC, 256 QAM, symbol rate:6952 Msps @ 850 MHz)

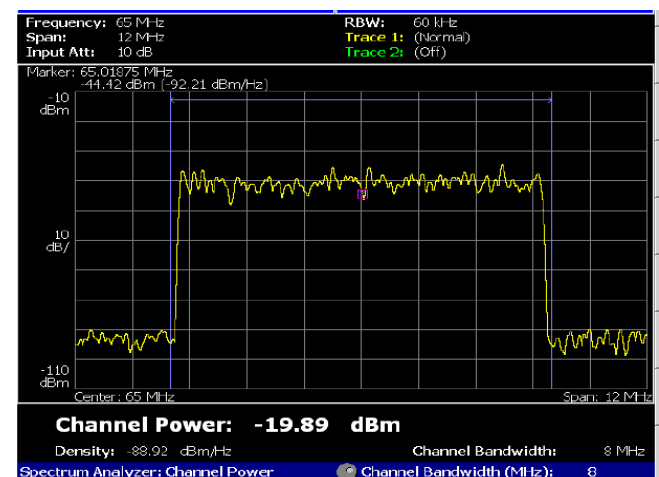

Figure 6: DVBT 8MHz, Mode -8K, 64 - QAM @ 65MHz

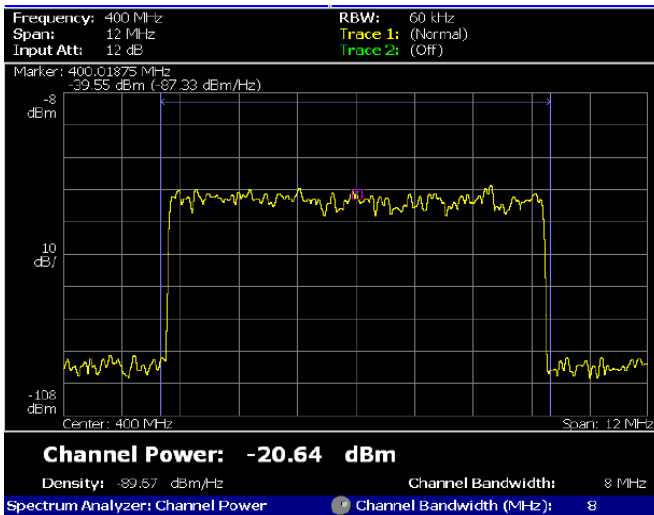

Figure7: DVBT 8MHz, Mode -8K, 64 - QAM @ 400 MHz

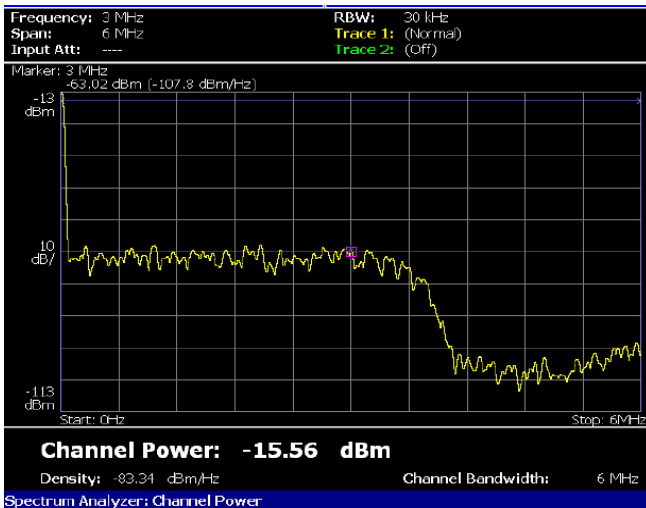

Figure 8: ZIF output from the modulator for DVBC

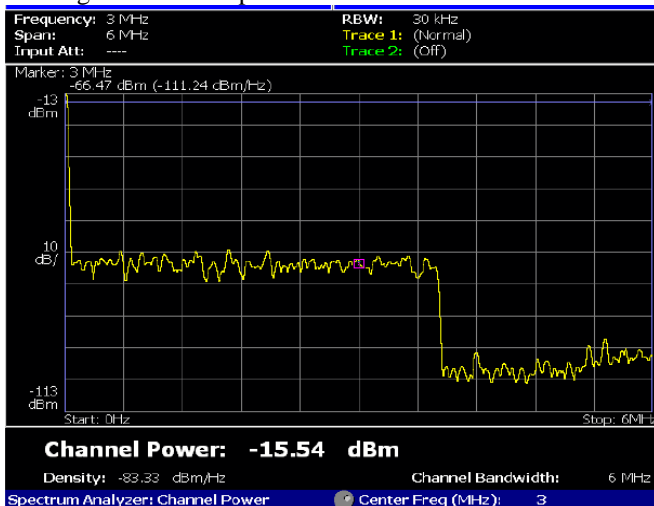

Figure 9: ZIF output from the modulator for DVBT

The above captured waveforms are taken before the signal amplification. With amplifier, the output level will can be increased to -5 dBm to 0 dBm, depending on the gain setting.

Table 2 shows the SNR for the different frequencies of DVBC and DVBT signal.

Table 2: SNR for DVBC /T

Standard	RF Frequency	SNR/MER
DVB-T , 8MHz, Mode-8K, 64-QAM, GI-1/32, CR- 3/4	50MHz	30.1 dB to 31.4 dB
	100MHz	29.9 dB to 30.6 dB
	350MHz	30.4 dB to 31.3 dB
	500MHz	30.4 dB to 31.2 dB
	850MHz	29.2 dB to 30.8 dB
DVB-C , 256 - QAM, Symbol Rate : 6.952 Mps	60MHz	32.3 dB to 32.8 dB
	250MHz	32.9 dB to 33.4 dB
	666MHz	38.4 dB to 39.3 dB
	745MHz	38.4 dB to 39.8 dB
	875MHz	32.2 dB to 32.8 dB

VI. CONCLUSION

Modulators used for commercial TV channel distribution must be of good quality output. The problems due to harmonics can be minimised by using filter bank circuits, which can give image suppression of 40 dB. The output from the amplifier can be DVBC or DVBT depending on the modulation used in the first stage. For Terrestrial transmission, the amplifier at the output stage is essential. By using suitable antenna at the output of ampler stage, the signal can be transmitted over air for the DVBT applications

REFERENCES

- [1] Rabindra K. Mishra "Architecture and system design aspect of RF Front – end blocks for an advanced CATV STB Converter" International Journal of Information Technology and knowledge Management, July –Dec 2012, Vol 5, No. 2, PP409 – 412
- [2] Bhalchandra B. Godbole, Dilip S. Aldar "Performance Improvement by Changing Modulation methods for software defined radios", (IJACSA) International Journal of Advanced Computer Science and Applications, Vol. 1, No. 6, December 2010
- [3] Nerey H Mvungi, "Set top box for Terrestrial Digital Broadcasting : Compatibility Issues" ICCSIT 2011, Pattaya, Dec. 2011
- [4] Seung Jun Lee " A precisely gain controlled RF front end for T-DMB Tuner ICs" IEICE 2012 , Vol 9, No. 1, pp 23 -29, Jan 10, 2012
- [5] Han Kefeng , "A wide band CMOS VGLNA based on single to differential stage and resistive attenuator for TV Tuners", Journal of semiconductors, Vol 32, No. 7, July 2011
- [6] Donggu Im, "A wide band CMOS LNA for digital TV Tuners" IEEE Journal of solid state circuits, Vol.44, No.3, March 2009
- [7] Supisa, "A 48 to 860 MHz, CMOS Low IF direct conversion DTV Tuner", IEEE Journal of Solid state circuits, Vol 43, No.9, Sept 2008
- [8] RF front end solutions from Silicon labs documents 2013, www.silabs.com
- [9] Applications notes from RFMD, www.rfmd.com
- [10] RF design solutions from NXP, www.nxp.com & www.nxp.com/pip/TDA18274HN, 2013
- [11] Technical papers from Marvell, www.marvell.com
- [12] Technical paper on " Challenges of Silicon Tv Tuner design", EE Times, April 2008
- [13] Application notes and technical papers from Coilcraft at http://www.coilcraft.com/appnotes.cfm
- [14] D. Im, H.-T. Kim, and K. Lee , "A CMOS resistive feedback differential low-noise amplifier with enhanced loop gain for digital TV

tuner applications,” IEEE Trans. Microw. Theory Tech., vol. 57, no. 11, pp. 2633–2642, Nov. 2009.

Nanda kishora Holla

Holds B.E., in Electronics and communication Engineering from University of Mysore and M.Tech in VLSI design and Embedded system from VTU .Belgaum

Presently enrolled as research scholar at VTU Extension Center, UTL Technologies, Bnaglore, India

Has more than 25 years of industrial and research experience in the field of RF and High frequency product development

Dr. Siva S. Yellapalli

Has Phd in Micro electronics and working as Professor at VTU Extension Center, UTL technologies, Bangalore .

Has published several technical papers and guided several research students for PhD degree.

Areas of concentration are hardware design, VLSI, integrated circuit design, and embedded systems. Currently working in the Research and Training Division at UTL,

Expertise and experience can be summarized as follows: -Proficient in systems level design and validation using microprocessors, ADCs, DACs, and FPGAs.

-Strong problem solving techniques and excellent lab debugging skills.

-Extensive academic and research experience in IC design, VLSI, MOS and bipolar devices, semiconductor device physics, and device modeling.

-Experience with L-Edit, Cadence, SPICE, VHDL, Verilog, C/C++, MATLAB, LabView.

-Published several papers in IC design for peer-reviewed journals and international conferences.