

# 5 PEN PC TECHNOLOGY

Mr.A.Raghuram, Mr.CH.Adibabu

**Abstract**— Five pen pc shortly called as P-ISM (Pen -style Personal Networking Gadget Package ), is nothing but the new discovery, which is under developing stage by NEC Corporation. P-ISM is a gadget package including five functions: a CPU pen, communication pen with a cellular phone function, virtual keyboard, a very small projector, and a camera. P-ISM's are connected with one another through short-range wireless technology. The whole set is also connected to the Internet through the cellular phone function. This personal gadget in a minimalist pen style enables the ultimate ubiquitous computing.

**Index Terms**— Five pen pc, P-ISM, Pen -style Personal Networking Gadget Package, NEC Corporation.

## I. INTRODUCTION

P-ISM ("Pen-style Personal Networking Gadget Package"), which is nothing but the new discovery, which is under developing, stage by NEC Corporation. P-ISM is a gadget package including five functions: a pen-style cellular phone with a handwriting data input function, virtual keyboard, a very small projector, camera scanner, and personal ID key with cashless pass function. P-ISMs are connected with one another through short-range wireless technology. The whole set is also connected to the Internet through the cellular phone function. This personal gadget in a minimalist pen style enables the ultimate ubiquitous computing. It is shown below



### P-ISM:

"P-ISM Pen-style Personal Networking Gadget Package".  
P-ISM is a gadget package including five functions

**Manuscript received September 21, 2014.**

Mr. A.Raghuram, Department Of Electronics and Communication Engineering, Indira Institute of Technology & Sciences Markapur  
Mr.CH.Adibabu, Department Of Electronics and Communication Engineering, Indira Institute of Technology & Sciences Markapur

## II. BACKGROUND

**Origins:** It seems to many of us these days that the pace of technological change is so great that it outstrips our imaginations just as soon as we can conceive of the next nifty electronic gadget we'd like to have, we find out that somebody has already built it. Miniaturized devices such as cameras and telephones are examples of now common technologies that just a few years ago most of us rarely encountered outside the fictional world of spy thrillers. Miniaturized personal computers are the next logical step, but many readers might be surprised to learn that a plan for PC components housed in devices the size and shape of ballpoint pens (as shown above) was showcased by a major electronics company over two years ago. At the 2003 ITU Telecom World exhibition held in Geneva, the Tokyo-based NEC Corporation displayed a conceptual prototype of what they dubbed a "Pen-style Personal Networking Gadget Package," or P-ISM. As NEC described the following component.

### A. PISM:

P-ISM is a gadget package including five functions: a pen-style cellular phone with a handwriting data input function, virtual keyboard, a very small projector, camera scanner, and personal ID key with cashless pass function. P-ISMs are connected with one another through short-range wireless technology. The whole set is also connected to the Internet through the cellular phone function. This personal gadget in a minimalistic pen style enables the ultimate ubiquitous computing.

The P-ISM system was based on "low-cost electronic perception technology" produced by the San Jose, California, firm of Canesta, Inc., developers of technologies such as the "virtual keyboard" (although the last two pictures shown above appear to be virtual keyboard products sold by other companies such as VKB rather than components of the P-ISM prototype)



Figure 1 :- Block diagram of P-ISM is shown below

B. CPU pen:

The functionality of the CPU is done by one of the pen. It is also known as computing engine.

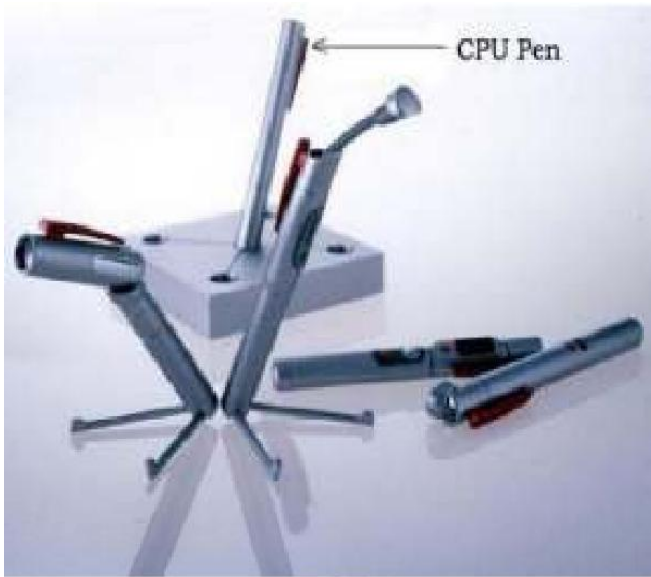

Figure 2 : CPU Pen

C. COMMUNICATION PEN:-

P-ISMs are connected with one another through short-range wireless technology. The whole set is also connected to the Internet through the cellular phone function. They are connected through Tri-wireless modes (Blue tooth, 802.11B/G, and Cellular) which are made small and kept in a small pen like device.



Figure 3 : Communication Pen

In fact, no-one expects much activity on 802.11n installations until the middle of 2008. “Rolling out 802.11n would mean a big upgrade for customers who already have full Wi-Fi coverage, and would be a complex adds networks, for those who haven't. Bluetooth is widely used because we can able to transfer data or make connections without wires. This is very effective because we can able to connect whenever we need without having wires. They are used at the frequency band of 2.4 GHz ISM (although they use different access mechanisms).

Blue tooth mechanism is used for exchanging signal status information between two devices. This techniques have been developed that do not require communication between the two devices (such as Blue tooth's Adaptive Frequency Hopping), the most efficient and comprehensive solution for the most serious problems can be accomplished by silicon vendors. They can implement information exchange capabilities within the designs of the Blue tooth. The circuit diagram for the 802.11B/G is given below. It is nothing but also type of Blue tooth. Using this connectivity we can also connect it with the internet and can access it anywhere in the world.

Concept Component	Function	Reliability
CPU Pen	Computing Engine	Open
Communication Pen	Cell Phone,Pressure Sensitive Pointing Device,Pointer and ear piece.Communication s using Bluetooth	Near Term
Display	LED Projector A4 Size Approx.1021 X 768	Slightly Father Out Than the Phone and Camera
Keyboard	Projected keyboard with 3D IR Sensor	Slightly Farther Out Than the Phone and Camera
Camera	Digital Camera	Near Term
Based	Battery Charger & mass storage	Open

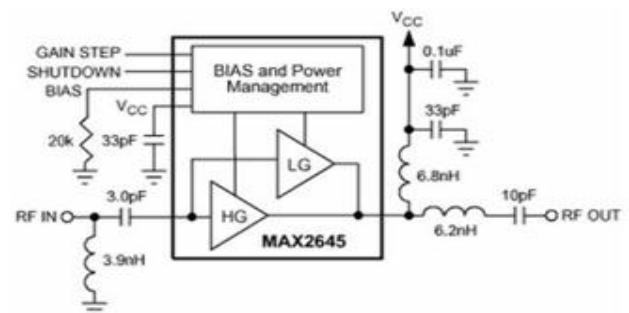

Figure 4: Block Diagram for Connectivity 802.11B/G and Blue tooth:

D. LED Projector:

The role of monitor is taken by LED Projector which projects on the screen. The size of the projector is of A4 size. It has the approximate resolution capacity of 1024 X 768. Thus it is gives more clarity and good picture.



Figure 5: LED Projector

#### E. Virtual Keyboard:

The Virtual Laser Keyboard (VKB) is the ULTIMATE new gadget for PC users. The VKB emits laser on to the desk where it looks like the keyboard having QWERTY arrangement of keys i.e., it uses a laser beam to generate a full-size perfectly operating laser keyboard that smoothly connects to of PC and Most of the handheld devices (PDA's, tablet PC's).The I-Tech laser keyboard acts exactly like any other "ordinary" keyboard[2,4]

#### Features of virtual keyboards are:

- 1.VKB settings can be changed by Sound:
- 2.Controllable Virtual Keyboard sound effects (key clicks)
- 3.Connection: Connection to the appropriate Laptop/PC port
- 4.Intensity: Intensity of the projected Virtual Keyboard
5. Timeouts: coordinated timeouts to conserve the Virtual Keyboard's battery life
- 6.Sensitivity: adjustable sensitivity of the Virtual Keyboard
7. Auto-repeat: Allows the VKB to automatically repeat a key based on prescribed parameters.

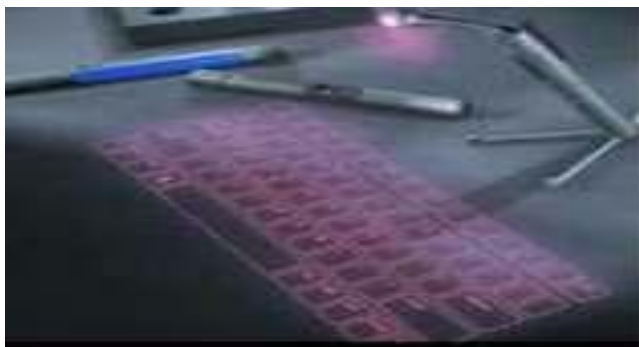

Figure 6: Virtual Keyboard

#### F. Digital Camera:

We had digital camera in the shape of pen .It is useful in video recording, video conferencing, simply it is called as web cam. It is also connected with other devices through Blue tooth. The major advantage it is small which is easily portable. It is a 360-Degree Visual Communication Device. We have seen video phones hundreds of times in movies. However, why can't we act naturally in front of videophone cameras? Conventional visual communications at a distance have been limited due to the display devices and terminals. This terminal enables showing of the surrounding atmosphere and group-to-group communication with a round display and a

central super-wide-angle camera



Figure 7 : Digital Camera

#### G. Battery:

The most important part in the portable type of computer is its battery. Usually batteries must be small in size and work for longer time. It comes with a battery life of 6+. For normal use it can be used for 2 weeks. This 'pen sort of instrument' produces both the monitor as well as the keyboard on any flat surfaces from where you can carry out functions you would normally do on your desktop computer



### III. CONCLUSINON

The communication devices are becoming smaller and compact. This is only an example for the start of this new technology. We can expect more such developments in the future.

### REFERENCES

- [1]Benlloch-Dualade,J.V,Buendia.F,Cano.J,"On the design of interactive classroom environments based on the tablet PC Technology" Frontiers in Education Conference (FIE), 2010 IEEE , Page(s): T4C-1 - T4C-6 , year:2010.
- [2]Choa Li, Bellarmine, G.T, Prosper.L"Tablet PC as innovative technology in Electronics Engineering Technology (EET) course delievery (non-refered)" South east 2009 IEEE page(s):443, year:2009.
- [3]Stanton.K ,"Work in progress-enhancement of problem solving techniques with tablet PC-based learning technologies "Frontiers in education conference,2008,38th annual, Page(s): S4D-25 - S4D-26 , year: 2008.
- [4][www.athourstream.com](http://www.athourstream.com)
- [5][www.seminartopic.com](http://www.seminartopic.com)