

DESIGN OF HIGH PASS FILTER USING OTA

Tarun Kumar Das, Sanchita Basu, Ashish Srivastava

Abstract— A high-pass filter (HPF) is an electronic filter that passes high frequency signals but attenuates (reduces the amplitude of) signals with frequencies lower than the cutoff frequency. The actual amount of attenuation for each frequency varies from filter to filter. A high-pass filter is usually modeled as a linear time-invariant system. It is sometimes called a low-cut filter or bass-cut filter. The paper describes the designing of this high pass filter using OTA. The use of this element reduces cost drastically and has a good response. An experiment was conducted through this component which provided better result.

Index Terms— High pass filter, OTA.

I. INTRODUCTION

The desire for portability of electrical equipment generated a need for low power systems in battery operated products like hearing aids, implantable cardiac pacemakers, cell phones, and hand held multimedia terminals. Low power dissipation is attractive, and perhaps even essential in these applications to have reasonable battery life and weight. The ultimate goal in design is close to having low-battery systems, because the battery contributes greatly to volume and weight.

Circuit operation at reduced voltages is a common practice adopted to reduce power consumption. However, the circuit performance degrades and one gets low circuit bandwidth and voltage swings at low voltages. Scaling down the threshold voltage of MOSFETs compensates for this performance loss to some degree, but this result in increased static power dissipation. Analog circuits benefit marginally from scaling, as the minimum size transistors cannot be used in analog circuits because of noise and offset voltage constraints. However, scaling results in better performance in digital circuits

components of power dissipation in any circuit, namely, dynamic power caused by charging and discharging of (usually parasitic) capacitance, static power due to non-zero current of MOSFETs in the OFF state in digital circuits or biasing current in analog circuits, and the short-circuit power due to current flowing during the lapse of time when both PMOS and NMOS transistors are in the on state.

Manuscript received September 20, 2013

Tarun Kumar Das, assistant professor, , Electronics & Communication Engineering at Future Institute of Engineering & Management under West Bengal University of Technology, Kolkata, India.

Sanchita Basu, Electronics & Communication Engineering at Future Institute of Engineering & Management under West Bengal University of Technology, Kolkata, India.

Ashish Srivastava, Electronics & Communication Engineering at Future Institute of Engineering & Management under West Bengal University of Technology, Kolkata, India.

A. Design of High Pass Filter

A general structure of 1st order High Pass Filter is shown below which is to be modified using OTA

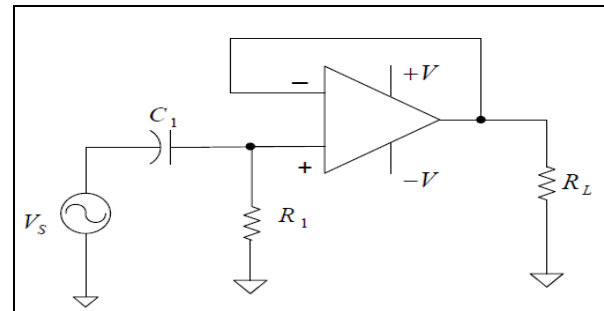

Fig-1

A high-pass filter (HPF) is an electronic filter that passes high-frequency signals but attenuates (reduces the amplitude of) signals with frequencies lower than the cutoff frequency. The actual amount of attenuation for each frequency varies from filter to filter. A high-pass filter is usually modeled as a linear time-invariant system. It is sometimes called a low-cut filter or bass-cut filter. High-pass filters have many uses, such as blocking DC from circuitry sensitive to non-zero average voltages or RF devices. They can also be used in conjunction with a low-pass filter to make a band pass filter.

II. PROPOSED WORK

We have proposed the use of OTA in the construction of High Pass Filter.

A. OTA (Operational Transconductance Amplifier)

Operational transconductance amplifiers (OTAs) are usable from the low audio range, but extends to applications at hundreds of megahertz, avoid operational amplifiers altogether and instead obtain the required gain in the form of transconductance. Whereas operational amplifiers, as we know, are voltage-controlled voltage sources, transconductance amplifiers are voltage-controlled current sources, $I_{out} = g_m V_{in}$. A macro model and an ideal model of OTA is the following:

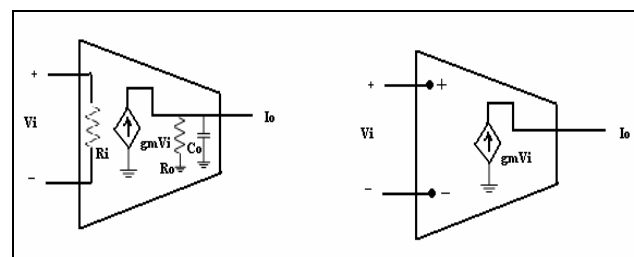

Fig 2: A macro model and an ideal model for OTA.

DESIGN OF HIGH PASS FILTER USING OTA

This design method generally uses only transconductance amplifiers and capacitors and is referred, therefore, as the *transconductance-C* (or *gm-C*) method. *Gm-C* filters are aimed specifically at high frequency integrated filters and at this time the dominant circuits for these applications.

OTA Fundamentals:-

The OTA is a transconductance device in which the input voltage controls the output current. The transconductance g_m makes the OTA as voltage controlled current source; whereas the op-amps are voltage controlled voltage source. An ideal OTA is defined by

$I_O = g_m (V^+ - V^-)$.
Where input & output impedances are infinite.

The transconductance g_m is directly proportional to control bias current I_b .
Characteristics of Ideal OTA can be summarized as follows:
Input impedance (Z_{in}) = ∞
Output Impedance (Z_o) = ∞
Inverting input current I_{O-} = Non-inverting input current I_{O+}
Bandwidth = ∞
The Figures 1.2 & 1.3 shows the basic schematic and equivalent circuit of OTA.

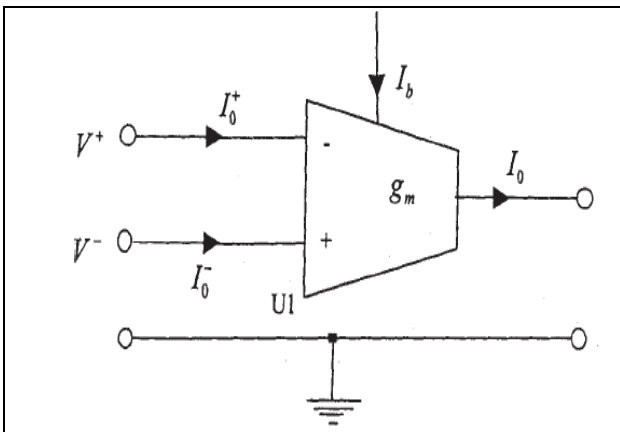

Fig 3: Circuit symbol of OTA

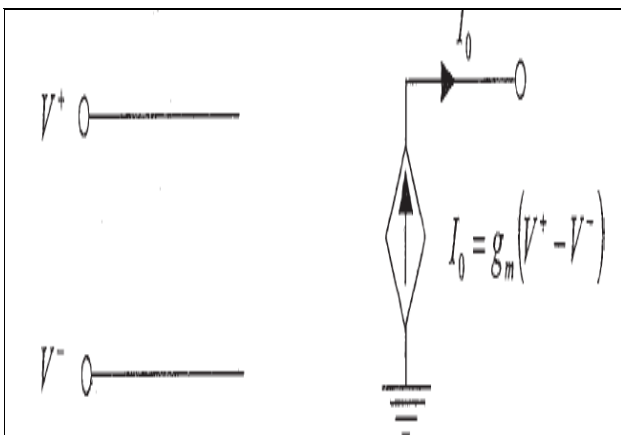

Fig 4: Small signal equivalent circuit of OTA

Current Mirror:-

The current mirror active load is a way to accomplish high gain for a single stage differential amplifier. The NPN transistors Q1 and Q2 shown make up the differential amplifier and Q3 and Q4 (PNP) make up the current mirror. The current mirror acts as the collector load and provide a high effective collector load resistance, increasing the gain. Such a device can produce a gain of 5000 or more with no load, but drops precipitously with loading. It is used in feedback loops and as a comparator. Current mirrors are used in the 741 op-amp.

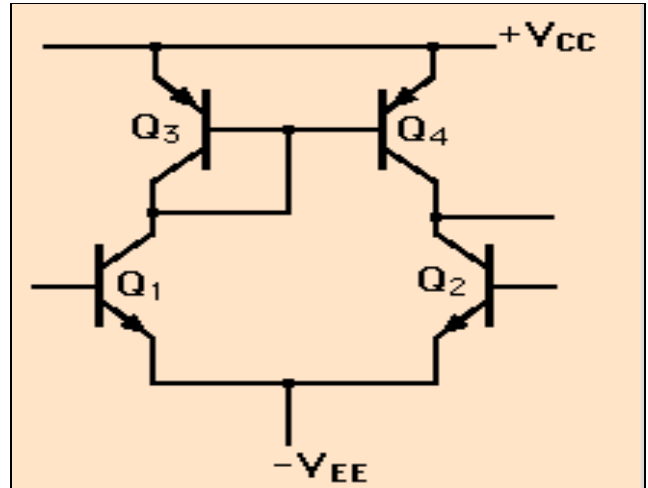

Fig: - 5

B. Design of First Order High Pass Filter

A high pass filter actually happens to be a device that modulates amplitude of frequencies, so that it is lower than the cut-off frequency. In certain circumstances, it actually a filter, which is very much a predominant in the electronic industry and it, has a variety of purposes, that can ensure that it has longevity along with the various features, that is very much essential for that specific industry. With it is actually modeled on a linear time, along with an invariant system, that is directly proportional to the amount of frequency that is given off by the device, and also reduces the amplitude that is required, hence making sure that the frequency is always below the cut-off frequency.

In common terms, are *high pass filter* is basically a bass cutting filter, that can ensure that there is no huge amount of frequency that is needed to be modulated, and you need not worry about getting a lot of feedback from the device, because of the fact that the amplitude would be way less than the cut-off frequency, so that frequency would not be lost in the current passage of transmission. They are utilized for a lot of features like blocking direct current and also ensuring that the voltage of the radio-frequency device is placed in the optimum level.

A schematic Diagram of 1st order High Pass Filter is shown below-

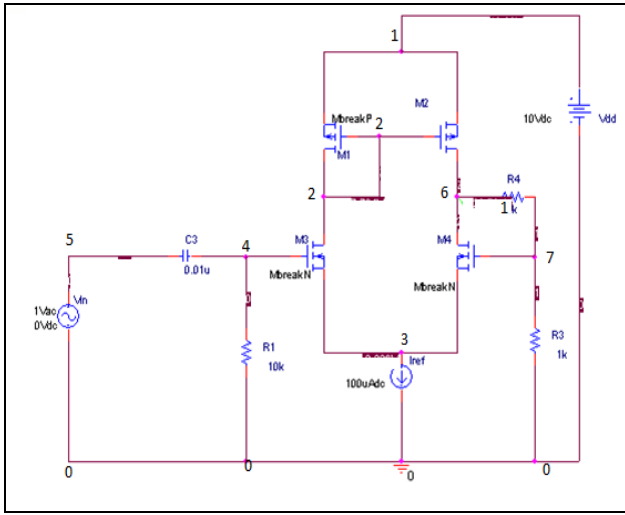

Fig 6: 1st order high pass filter using OTA

These circuits have the same output as single stage passive filters. Since the RC filter is connected to high impedance input of the non-inverting amplifier, the RC filter will not be loaded to the next stage. It is possible to replace the op-amp follower circuit with an op-amp non-inverting amplifier to obtain voltage gain.

Filters can be classified by the steepness of their roll-off. The roll-off is a measurement of how a reference output signal in the pass-band to the output signal at a given frequency beyond cut-off. Fig 2.5 shows the bode plot for three different order of filters. The passive filters are limited to a roll-off of 20db/decade or 6db/octave and are called first order passive filters. A roll-off of 20db/decade means that as the frequency is increased by 10 times, the amplitude of the output signal is reduced to one-tenth. First order filters use only one RC network and are also called single-pole filters.

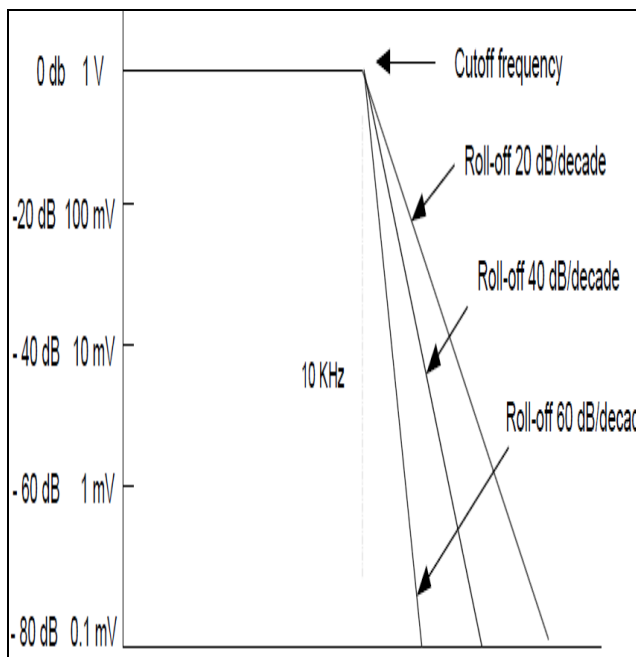

Fig 7: Bode plot of different order filters

A schematic Diagram of 2nd order High Pass Filter is shown below-

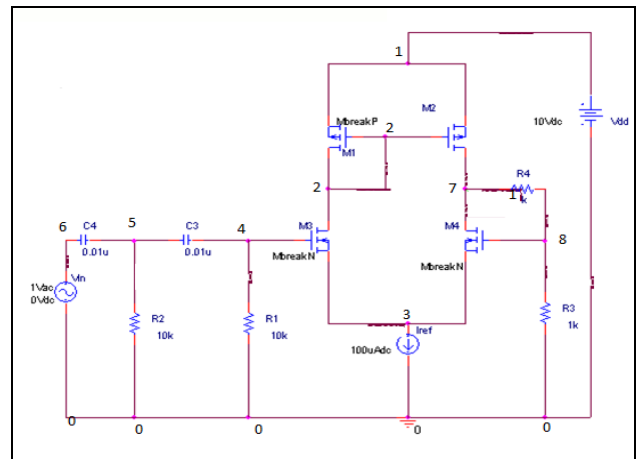

Fig-8

III. AND ANALYSIS:-

For 1st Order High Pass Filter:-

Theoretical Result:

$$\text{cut-off frequency } f_c = 1/(2\pi R_1 C_3)$$

So, the theoretical value of cut-off frequency of 1st order high pass filter is $f_c = 1/(2\pi * 10K * 0.01\mu F)$

$$f_c = 1.59 \text{ KHz}$$

Magnitude plot of 1st order high pass filter:

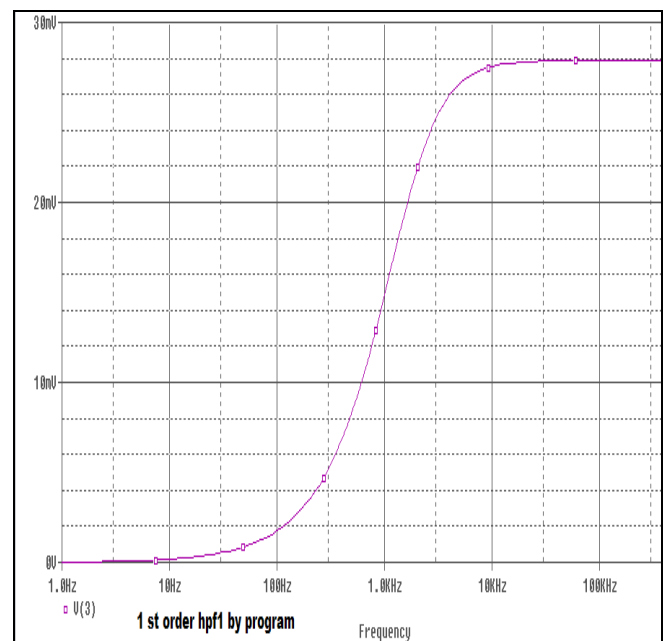

Fig 9 : Output voltage magnitude vs input frequency plot (Frequency Response)

Gain plot of 1st order high pass filter:

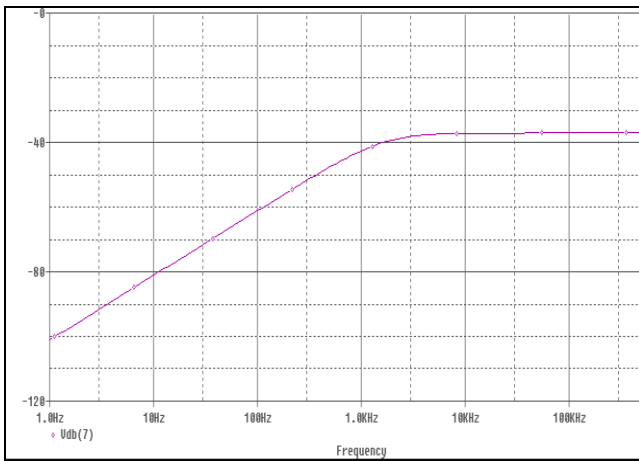

FIG 10: GAIN IN DB VS INPUT FREQUENCY PLOT OF 1ST ORDER HIGH PASS

Practical Result:

From the gain plot of 1st order high pass filter we obtain the cut-off frequency (from the gain curve by downing 3-dB from the top point) $f_c = 1.54\text{KHz}$ (approx)

Phase plot of 1st order high pass filter:

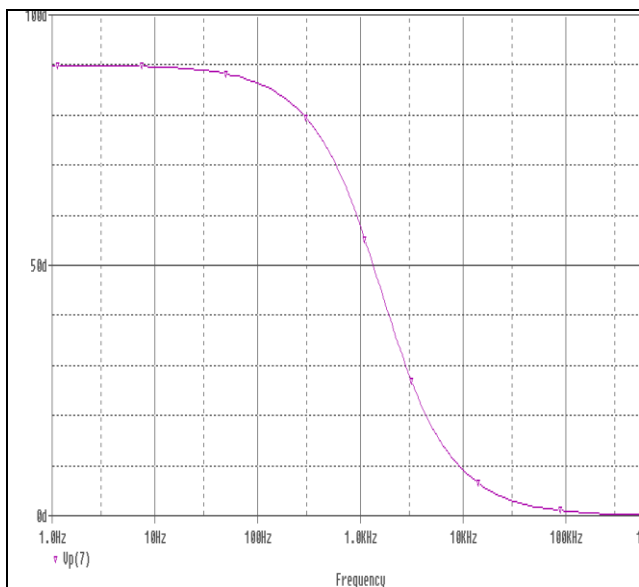

Fig 11: Phase vs input frequency plot of 1st order high pass filter

For 2nd Order High Pass Filter:-

Theoretical Result:

$$\text{Cut-off frequency } f_c = 1/2\pi\sqrt{R_1R_2C_3C_4}$$

So, from the practical circuit diagram the cut-off frequency of 2nd order high pass filter is

$$f_c = 1/2\pi\sqrt{10K * 10K * 0.01\mu F * 0.01\mu F} = 1.59\text{KHz.}$$

Magnitude plot of 2nd order high pass filter:

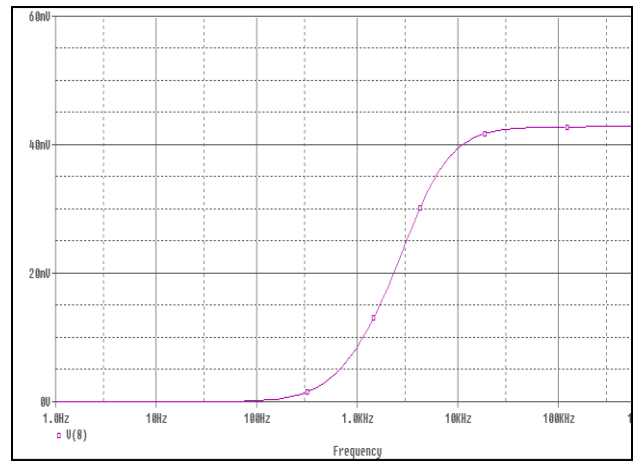

Fig 12 : Output voltage magnitude vs input frequency plot (Frequency Response)

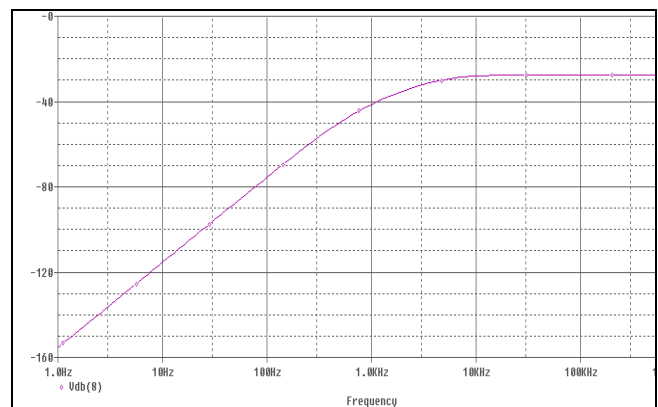

Fig 13 : Gain in db vs input frequency plot of 2nd order high pass filter

Practical Result:

From the gain plot of 2nd order high pass filter we obtain the cut-off frequency (from the gain curve by downing 3-dB from the top point) $f_c = 1.63\text{KHz}$ (approx)

Phase plot of 2nd order high pass filter:

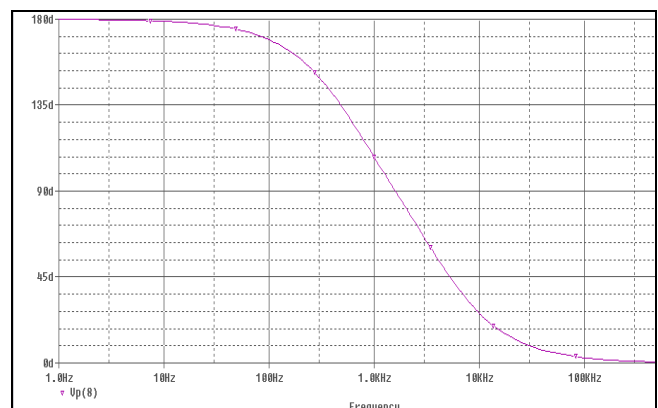

Fig 14 : Phase vs input frequency plot of 2nd order high pass filter

A. *Advantages:-*

- a. The conventional operational amplifier (op-amp) is used as the active device in the vast majority of the active filter literature. A host of practical filter designs have evolved following this approach. It has also become apparent, however, that operational amplifier limitations preclude the use of these filters at high frequencies, attempts to integrate these filters have been unsuccessful (with the exception of a few no demanding applications), and convenient voltage or current control schemes for externally adjusting the filter characteristics do not exist.
- b. These structures offer improvements in design simplicity and programmability when compared to op-amp based structures as well as reduced component count.
- c. All transistors in the circuit are operated in the weak inversion region so that the low supply voltage and very low power consumption is also achieved.
- d. Two important characteristics of CMOS devices are high noise immunity and low static power consumption. Since one transistor of the pair is always off, the series combination draws significant power only momentarily during switching between on and off states.
- e. Consequently, CMOS devices do not produce as much waste heat as other forms of logic, for example transistor-transistor logic (TTL) or NMOS logic, which normally have some standing current even when not changing state.

IV. CONCLUSION

In this work, a circuit based on the sub-threshold operation of MOS transistors is proposed for the design of low-frequency OTA-C active filters. The design was simulated in pSpice using Level 49 parameters of BSIM3v3. The MOS transistors in the designed OTA operate in sub-threshold or weak inversion region, such that their drain currents are exponentially related to gate-to-source voltages, in the nA and even pA level. Sub-threshold CMOS circuit design is very difficult, since the governing equations that model the behavior of the MOS transistor in weak inversion are so complicated. The most advantageous aspect of sub-threshold design is that the supply voltage can be decreased below 1 V. Using minimum number of transistors and other active elements, the sub-threshold design leads to very low-power operation of the devices. Therefore, this kind of design is suitable for biomedical instruments.

After accomplishing this project, it is observed slight difference between the theoretical result and practical result of the cut-off frequencies of the active filters (1st order low pass, 2nd order low pass, 1st order high pass, 2nd order high pass, 1st order band pass and 2nd order band pass filters). It has happened due to taking the measurements (during the

practical result) from the original gain plot graphs by manually.

OTAs are versatile building blocks that intrinsically offer wide bandwidth for many types of amplifiers. The OTA, or voltage-controlled current source, can be viewed as an ideal transistor. As the transistor model, it has three terminals: a high input impedance (base, or B); a low-impedance input/output (emitter, or E); and a current output (collector, or C). However, unlike a bipolar transistor, the OTA is self-biased and has bipolar output, meaning that the output current source can either source or sink the output current. The output current is zero for a zero base-emitter voltage. AC-inputs centered on zero produce an output current that is bipolar and also centered on zero. The transconductance element is traditionally adjustable with an external resistance, allowing trade-offs in bandwidth, quiescent current, and gain. So, Operational Transconductance Amplifiers are widely used in electronics world now-a-days.

V. FUTURE SCOPE

Due to the nature of wide screen topic, there are still several areas of Improvement for future work on this op-amp. Some applications are described below :

A. *OTA as voltage controlled oscillator:*

If you have a resistor that is referenced to the virtual ground of an operational amplifier, then it is easy to use an OTA to make that resistance voltage controlled. The resistor is replaced by a voltage divider to the real ground so that the divider puts out about 5 mV, which gets connected to the positive input of the OTA. The negative input is connected to ground as well, while the output of the OTA goes into the virtual ground of the operational amplifier. The apparent resistance can then be controlled by adjusting I0 accordingly.

B. *OTA IC:*

To facilitate easier analysis of the schematics in the various datasheets, the current mirrors are shown as ideal elements. Unfortunately most of these IC are discontinued as of May 2005.

The bipolar current mirrors come in two flavors: the simplest one is named after late (and legendary) Robert J. (Bob) Widlar and uses just two transistors. The base current of the transistors is not compensated for, so this mirror requires a relatively high transistor beta to work precisely enough. The second one, named after George Wilson, uses another transistor to compensate for the base current and improve dynamic output impedance at the expense of output voltage range. Actually there is another variant of the Wilson mirror that adds a fourth transistor that works even better at high current levels.

a. *The CA3080:*

The CA3080 is probably the most simple standalone bipolar OTA that you can find. It consists of only the input

differential pair and the current mirrors that bias the input transistors and produce the output current.

In particular, the mirror for the tail current is a simple Widlar type and emitter degeneration cannot be used as the tail current can vary widely. It is therefore important to keep the differential and current inputs at the same potential; otherwise the transconductance gets modulated by the common mode input voltage. Unfortunately the datasheet does not show the circuit for measuring the CMRR, but it appears that the common mode amplitude was low for the test and the input potentials about the same.

The output current mirrors are all Wilson type; the pnp mirrors also use a Darlington pair for the cascade transistor to get around the low beta of the pnp transistor in this process.

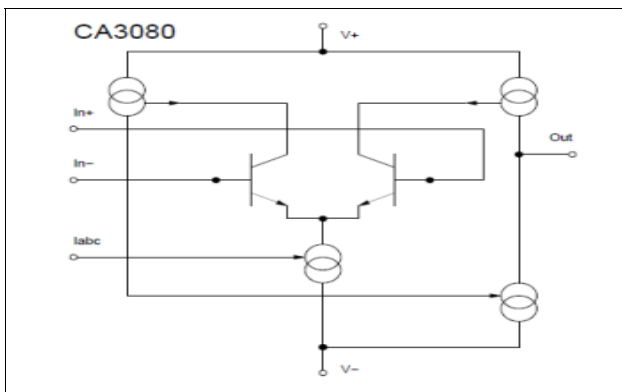

Fig 15: CA3080

Using minimum number of transistors and other active elements, the sub-threshold design leads to very low-power operation of the devices. These structures offer improvements in design simplicity and programmability when compared to op-amp based structures as well as reduced component count.

REFERENCES

[1] Operational Transconductance Amplifier by Archim Gratz
 [2] A low frequency operational transconductance amplifier (OTA) design and band pass filter implementation using OTA-C filter topology by Aydin Ozyavas
 [3] CMOS transconductance amplifier, architectures and active filters: a tutorial by E. Sanchez-Sinencio and J. Silvia-Martinez
 [4] Realization of active filters using Operational Transconductance Amplifier (OTA) by Prashant k. Mahapatra, Manjeet Singh and Neelesh Kumar
 [5] Design of Two stage high gain operational amplifier using current buffer compensation for low power application by Sachin Kumar Rajput
 [6] I. N. Bronstein and K. A. Semendjajew, *aschenbuch der Mathematik*. BSB Teubner, 24th ed., 1989.
 [7] D. Sauer, *The LM13600 Story*, May 2003. <http://www.idea2ic.com>.
 [8] H. Camenzind, *Designing Analog Chips*. Virtualbookworm.com Publishers, 2005. <http://www.designinganalogchips.com>.
 [9] T. H. Wilmshurst, *Analog Circuit Techniques with Digital Interfacing*. Newnes, 2001.
 [10] Intersil Americas Inc., CA3080, CA3080A: 2MHz, Operational Transconductance Amplifier (OTA), Aug. 2004. FN475.6.
 [11] http://en.wikipedia.org/wiki/Operational_transconductance_amplifier
 [12] <http://synth.stromeko.net/diy/OTA.pdf>

[13] <http://technologyinterface.nmsu.edu/winter98/electronics/grise/wrg.html>
 [14] <http://technologyinterface.nmsu.edu/winter98/electronics/grise/wrg.html>
 [15] <http://www2.imse-cnm.csic.es/~bernabe/jssc89.pdf>
 [16] <http://www.ti.com/lit/an/sboa117/sboa117.pdf>
 [17] <http://books.google.co.in/books?id=ZW9n83RnOOEC&pg=PA6&pg=PA6&dq=future+scope+of+operational+transconductance+amplifier&so>



Tarun Kumar Das, assistant professor in Electronics & Communication Engineering at Future Institute of Engineering & Management under West Bengal University of Technology. His research interest includes control system and signals and systems.



Sanchita Basu, currently pursuing B.Tech in Electronics & Communication Engineering at Future Institute of Engineering & Management under West Bengal University of Technology. Her research interest includes control



Ashish Srivastava, currently pursuing B.Tech in Electronics & Communication Engineering at Future Institute of Engineering & Management under West Bengal University of Technology. His research interest includes control system and wireless communication.