

# ADAPTIVE BLIND NOISE SUPPRESSION

Avinash Kumar Jha, Vijay Kumar Swamy, Ranjan Kumar

**Abstract**— Noise is a random and more accurately a stochastic process. Noise is a vital element in all speech processing systems, which is quite broadband. This means that we will have to narrow down the noise bandwidth so as to receive an input signal noise free or with minimum noise at the output after processing. Presently, Narrow Band Notch filters are being used, which forms its basis upon the second order Gray-Markel lattice structure. These Notch filters are adaptive to track the variations in the characteristics of noise as because noise is random in nature. This system of filters are extensively used as it is merituos based on the fact that the system has very low computational complexity as well as its stable,in response to the random noise.

**Keywords**-Narrow Band Notch filters, Gray-Markel lattice structure.

## I. INTRODUCTION

All the speech processing applications are being contaminated by noise. Noise is the negative element which plays a spoil-sport in the performance of the Speech Codecs. In the hands free phone systems, the background noise inevitably lowers and hence degrades the signal to noise ratio, thereby results in the degradation of the performance of the system. Here arises the need and means to suppress this random signal i.e. to extract out the noise from the original message signal.

A classical System was designed in the process which could adapt to the variations in the characteristics of noise. These classical systems used adaptive linear filtering which formed its basis upon the applications of Digital Filtering with Finite Impulse Response. The linear approach of the system along with the stability of the FIR filters was the key element which shifted the tide in favour of the classical systems. Moreover, Least mean squares (LMS) and Recursive least squares (RLS) algorithms were used, which are well known adaptive algorithms to examine the response of the system. After this various kind of sytems were developed like non-linear Systems, system based upon microphone array,etc. Adaptive Blind Noise Suppression Scheme, abbreviated as ABNS

came into the light,which was based upon the Gray-Markel lattice structure.

### A. USED APPROACH FOR NOISE SUPPRESSION:

Adaptive Noise Suppression scheme has been widely adopted where the realization is based upon the Second Order Gray-Markel lattice structure, which in turn uses a Second order Notch Section. The merits for using such realization was because firstly, it could adapt to the variations in the noise characteristics very quickly with utmost ease and Secondly, it prevented any distortions in the speech signal by the application of Narrowband sections.

The Following circuit below is the second order Gray-Markel lattice circuit showing the ABNS scheme.

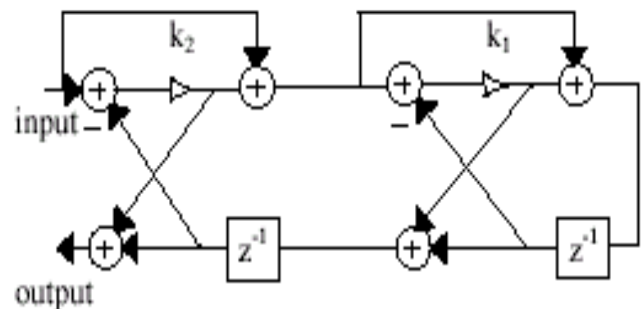

The Second order notch filter is as follows:

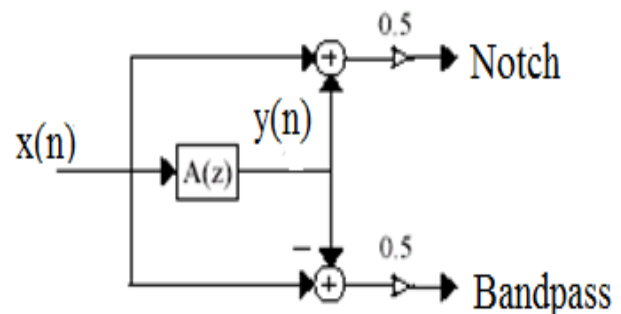

The adaptive noise suppression scheme is depicted below:

**Manuscript received August 20, 2013**

**Avinash Kumar Jha**, Electronics & Communication Engineering at Future Institute of Engineering & Management under West Bengal University of Technology, Kolkata, India.

**Viajy Swamy**, Electronics & Communication Engineering at Future Institute of Engineering & Management under West Bengal University of Technology, Kolkata, India.

**Ranjan Kumar**, Electronics & Communication Engineering at Future Institute of Engineering & Management under West Bengal University of Technology, Kolkata, India.

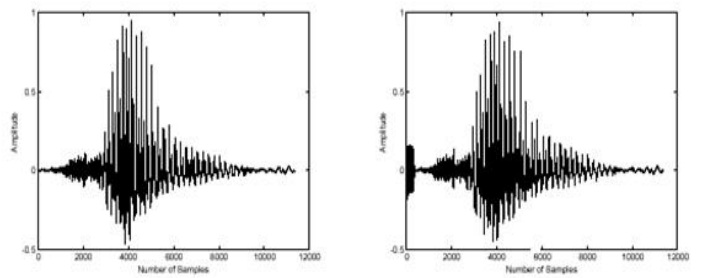
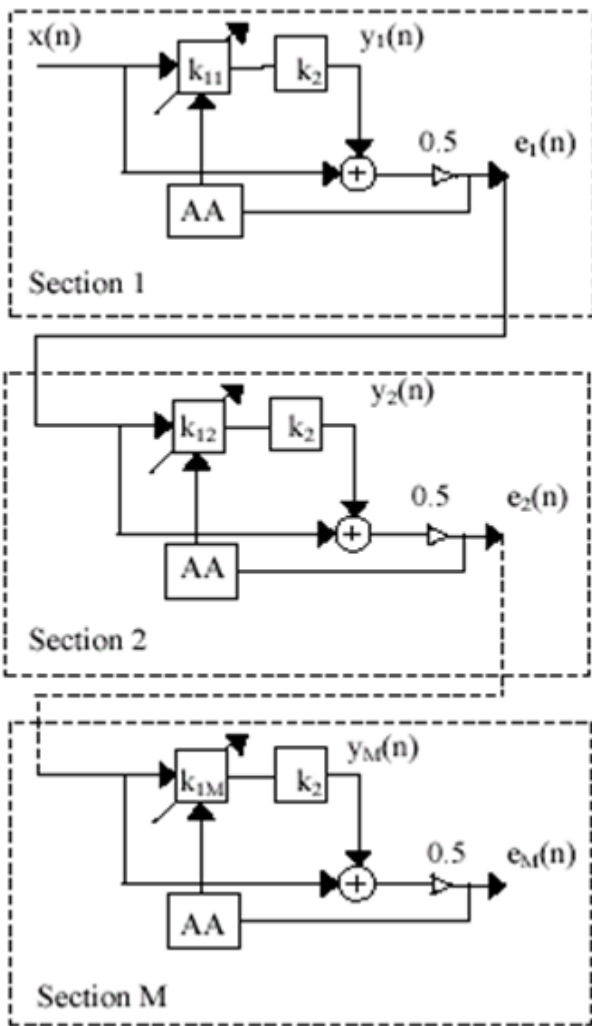

Original speech - the word "home".

Speech after noise suppression.

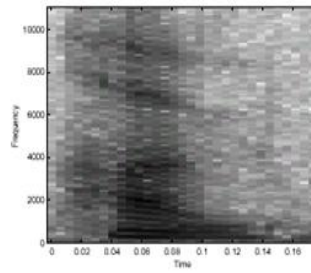

Spectrogram - the word "home".

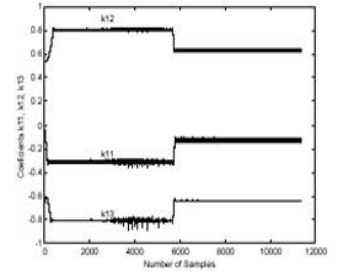

Trajectories of the filter coefficients.

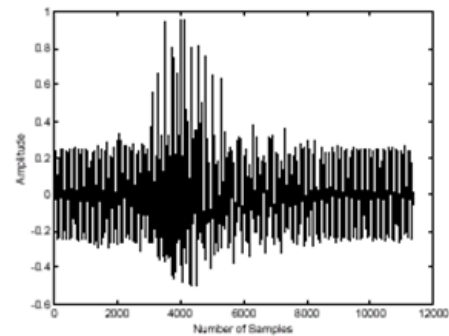

Noise-contaminated speech.

Test Results

The results are basically verified with the help of computer simulators and following graphs are observed:

II. PROPOSED WORK

In this paper, we have proposed two ways for adaptive blind noise suppression:

1. Use of Gamma Filter in place of Adaptive Notch Filter.
2. Use of Operational Amplifier(OP-AMP) In Notch Circuit.

A. Use Of Gamma Filter:-

Gamma Filter is a new class of Adaptive IIR Filter that combines the attractive properties of Finite Impulse Response (FIR) filters with some of the power of Infinite Impulse Response (IIR) filters. Preliminary results indicate that the adaptive gamma filter is more efficient than adaline in terms of minimum mean square error.

The gamma filter, a particular instance of the generalized feedforward filter, is analyzed in detail. The gamma filter borrows desirable features from both IIR and FIR systems -

trivial stability, easy adaptation and yet the decoupling between the region of support of the impulse response and the filter order.

The Gamma Filter in time domain is defined as :

$$Y(n) = \sum_{k=1}^K W_k X_k(n), \text{ where } X_k(n) = (1 - \mu) X_k(n-1) + \mu x_{k-1}(n-1),$$

The Circuit Diagram of a Gamma Filter is as follows:

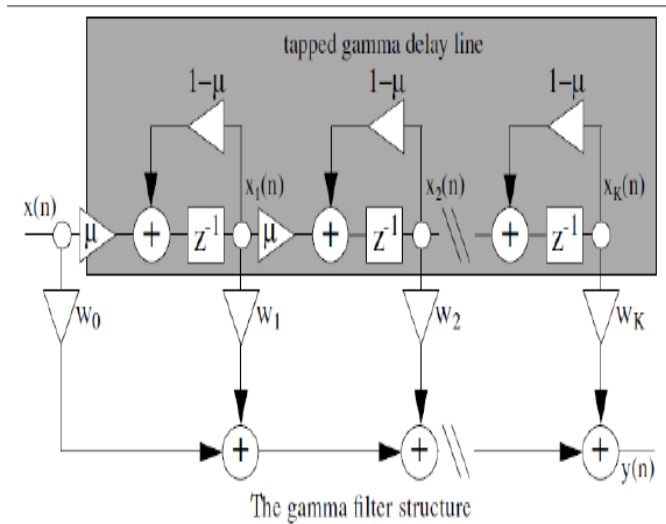

**B. Stability of Gamma Filters**

Due to the restricted nature of the feedback loops it is easily verified that stability of gamma filter is guaranteed when  $0 < \mu < 2$ .

In FIR and gamma filter structures, the number of adaptive parameters and the filter order are coupled (both K). Thus, when  $\mu = 1$ , the number of weights equals the memory depth. Very often this coupling leads to overfitting of the data set (using parameters to model the noise). Hence, the parameter  $\mu$  provides a means to decouple the memory order and depth.

**C. Features of Gamma Filter**

1. A new class of Adaptive IIR Filter which combines the features of both FIR Filter as well as IIR filter.
2. The gamma filter, a particular instance of the generalized feedforward filter, has trivial stability, easy adaptation and yet the decoupling between the region of support of the impulse response and the filter order.

**Advantages of Gamma Filter over Adaptive Notch Filter:-**

- The following table highlights the major advantage of using the gamma filter:

Kth order filter	FIR	GAMMA	IIR
STABILITY	always stable	trivial stability $0 < \mu < 2$	non-trivial stability
MEMORY DEPTH vs. ORDER	coupled K	decoupled $K/\mu$	decoupled
COMPLEXITY of ADAPTATION	$O(K)$	$O(K)$	$O(K^2)$

- From the above table, we see that the Complexity of adaptation of Gamma Filter is  $O(K)$ , which means it is linear and hence less complex.
- We also find the complexity of FIR filter to be same as that of the Gamma filter but Gamma filter is meritorious because it can adapt quickly to the variations in the characteristics of noise which FIR filter cannot.
- Gamma filter has guaranteed stability when  $0 < \mu < 2$ .
- Gamma filter also outperforms the conventional adaline by a large margin which is shown below:

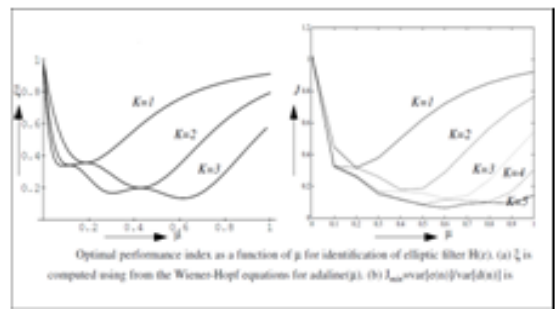

**D. Use Of OP-AMP:-**

A notch filter is used to remove a particular frequency, having a notch where signals are rejected. Often they have fixed frequency, but some are able to tune the notch frequency.

Operational amplifiers can be used to make notch filter circuits. Here, we show a standard notch filter circuit using

one op amp. We may use two OP-AMPS also to increase performance.

Having a fixed frequency, this operational amplifier based on notch filter circuit may find applications such as removing fixed frequency interference like hums from audio circuits.

The circuit diagram is shown below:-

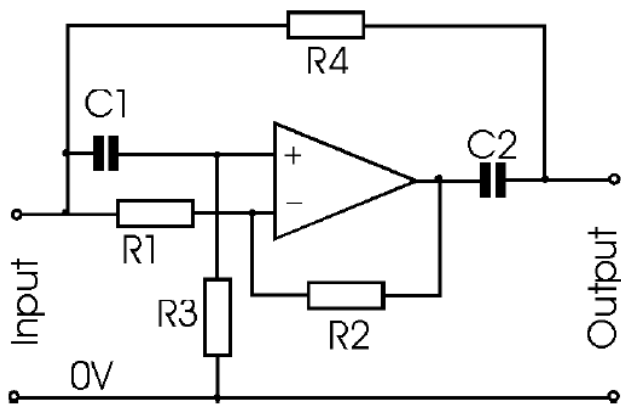

ADVANTAGES OF USING OP AMP IN NOTCH CIRCUIT.

1. Provides both negative and positive feedback around the operational amplifier chip and in this way it is able to provide a high degree of performance. It makes calculation easy such as...

$$F \text{ Notch} = 1 / (2 \pi R C)$$

Where

$$R=R3=R4, \\ C=C1=C2.$$

2. Uses high tolerance component, as the proper performance of a machine can depend on the tolerance specified for its parts, particularly those that must fit together for suitable relative motion.

3. This circuit is often used to remove unwanted signals such as hums.

4. Many circuit exhibit an increase in voltage noise spectral density (NSD) as they approach the unity-gain crossover frequency. This noise peaking can cause your circuits to have 39% higher noise than you expected. This is especially troublesome in unity-gain circuits, also called buffer or voltage-follower applications. Such peaking occurs when the spot noise becomes greater than the noise floor of the amplifier, and this behavior can extend for several octaves beyond crossover. This can be reduced by using op amps which increases SNR.

III. CONCLUSION

From our observation we can conclude the following points:

1. Gamma Filter is linear as its complexity of adaptation is only O(K).
2. Using Op-Amp in Notch circuit is used to remove unwanted signals such as hums and hence an Op-amp based circuit is of immense use.
3. By using Op-amp, the signal to noise ratio (S/N) would increase, which is desirable because it removes the noise part and hence suppresses the adaptive noise.
4. The gamma filters produce a remarkable compromise between these two extremes. In one hand, the decoupling between filter memory and filter order is kept, but due to the local recursiveness of the gamma topology, the application of the Wiener-Hopf optimization still yields an analytical solution that can be computed exactly in the frequency domain. Moreover the filter coefficients and memory depth parameter  $\mu$  can be adapted using the LMS algorithm, which produces an algorithmic complexity of O(K). The use of a global single parameter that controls the memory depth is very useful because stability can be easily ensured by requiring that  $\mu < 2$ .

IV. FUTURE WORK

We have proposed two ways by which we can suppress the Adaptive Blind Noise In Speech processing applications. However, we are working on other efficient ways by which this can be done. Our future work is related to the following:

1. Use of MOSFETs in place of OP-AMPS in the notch circuit as it would enhance further the Signal to Noise Ratio.
2. Use of gamma filter with enhanced stability as well as lesser delay possible so that it can adapt more rapidly to the variations in the noise signal.

REFERENCES

1. Amin M., " Sliding Spectra: a new perspective", Proc. 4th Ann. ASSP Workshop on Spectrum Estimation, pp 55- 59, 1988.
2. Perez H., Tsujii S., " A system identification algorithm using orthogonal functions", Trans. Signal Proc., vol 39, #3, 752-755, 1991.
3. de Vries B. and Principe J.C., " A Theory for Neural Nets with Time Delays. NIPS-90 Proceedings, Lippmann R., Moody J., and Touretzky D. (eds.), San Mateo, CA, Morgan Kaufmann, 1991.
4. Oppenheim A. and Schafer R., " Digital Signal Processing, Prentice-Hall, 1975.
5. Widrow B. and Stearns S., " Adaptive Signal Processing, Prentice-Hall, 1985.
6. Wiener N., " Extrapolation, Interpolation and Smoothing of Stationary Time Series with Engineering Applications, New York, Wiley, 1949.

7. Eric A. Wan and Rudolph van der Merwe, "Noise-Regularized Adaptive Filtering for Speech Enhancement," *Proc. Eurospeech*, pp. 2643-2646, 1999.
8. Ki Yong Lee., Byung-Gook Lee, Ickho Song, and Souguil Ann, "Robust Estimation of AR Parameters and its Application for Speech Enhancement," *Proc. IEEE ICASSP*, pp. 309 - 312, 1992.
9. Phil S. Whitehead, David V. Anderson, and Mark A. Clements, "Adaptive, Acoustic Noise Suppression for Speech Enhancement," *Proc. IEEE ICME*, pp. 565 – 568, 2003.
10. A. V. Oppenheim, E. Weinstein, K. C. Zangi, M. Feder, and D. Gauger, "Single Sensor Active Noise Cancellation Based on the EM Algorithm," *Proc. IEEE ICASSP*, pp. 277 – 280, 1992.
11. T. Rutkowski, A. Cichocki, and A. K. Barros, "Speech Enhancement Using Adaptive Filters and Independent Component Analysis Approach," *Proc. AISAT*, 2000.
12. H. Saruwatari, K. Sawai, A. Lee, K. Shikano, A. Kaminuma, and M. Sakata, "Speech Enhancement and Recognition in Car Environment Using Blind Source Separation and Subband Elimination Processing," *Proc. ICA*, pp. 367 – 372, 2003.
13. Simon Haykin, *Adaptive Filter Theory*, Prentice-Hall Inc., Upper Saddle River, NJ, pp 466 – 501, 2002.
14. M. T. Johnson, A. C. Lindgren, R. J. Povinelli, and X. Yuan, "Performance of Nonlinear Speech Enhancement using Phase Space Reconstruction," *Proc IEEE ICASSP*, pp. 872 – 875, 2003.
15. Andrew C. Lindgren, "Speech Recognition Using Features Extracted from Phase Space Reconstructions," *Thesis, Marquette University, Milwaukee WI*, May 2003.

#### AUTHORS PROFILE



**Avinash Kumar Jha**, currently pursuing B.Tech in Electronics & Communication Engineering at Future Institute of Engineering & Management under West Bengal University of Technology. His research interest includes control system and signals



**Vijay Swamy**, currently pursuing B.Tech in Electronics & Communication Engineering at Future Institute of Engineering & Management under West Bengal University of Technology. His research interest includes control system and wireless communication



**Ranjan Kumar**, currently pursuing B.Tech in Electronics & Communication Engineering at Future Institute of Engineering & Management under West Bengal University of Technology. His research interest includes control system and radar